

CBSE Class 10 Science
Sample Paper - 09

Maximum Marks: 80

Time Allowed: 3 hours

General Instructions:

- i. The question paper comprises three sections – A, B and C. Attempt all the sections.
- ii. All questions are compulsory.
- iii. Internal choice is given in each section.
- iv. All questions in Section A are one-mark questions comprising MCQ, VSA type and assertion-reason type questions. They are to be answered in one word or in one sentence.
- v. All questions in Section B are three-mark, short-answer type questions. These are to be answered in about 50 - 60 words each.
- vi. All questions in Section C are five-mark, long-answer type questions. These are to be answered in about 80 – 90 words each.
- vii. This question paper consists of a total of 30 questions.

Section A

1. Write a balanced chemical equation for the following reaction: Ethanol is warmed with ethanoic acid to form ethyl acetate in the presence of concentrated H_2SO_4 .
2. What happens to metallic character as we move from left to right in the periodic table?
3. **Answer the questions that follow on the basis of your understanding of the following paragraph and the related studied concepts:** In ancient times, wood was the most common source of heat energy. The energy of flowing water and wind was also used for limited activities. The exploitation of coal as a source of energy made the industrial revolution possible. Increasing industrialisation has led to a better quality of life all over the world. It has also caused the global demand for energy to grow at a tremendous rate. The growing demand for energy was largely met by fossil fuels –

coal and petroleum. Our technologies were also developed for using these energy sources. But these fuels were formed over millions of years ago and there are only limited reserves. Fossil fuels are non-renewable sources of energy, so we need to conserve them. If we were to continue consuming these sources at such alarming rates, we would soon run out of energy. In order to avoid this, alternate sources of energy were explored.



- i. What do you mean by non- renewable sources of energy?
 - ii. Write five examples of non-renewable energy sources.
 - iii. Which is the main element in fossil fuels?
 - iv. Which type of environmental hazard is not contributed by the combustion of fossil fuels?
4. Following questions are based on the two tables given below. Study these tables related to blood sugar levels and answer the questions that follow.

Table A (Blood glucose chart)

	Mean Blood Glucose Level (mg/dL)
Doctor's advice needed	380
	350
	315
	280
	250
	215
Good	180

	150
Excellent	115
	80
	50

Table B (Blood Report of Patient X and Y)

Time of check	Blood Glucose ranges (mg/dL)	
	Patient X	Patient Y
Before breakfast (Fasting)	<100	70-130
Before lunch, supper and snack	<110	70-130
Two hours after meals	<140	<180
Bedtime	<120	90-15

Answer the following questions:

- a. Refer to Table B showing the blood report of the levels of glucose of patients X and Y. Infer the disease which can be diagnosed from the given data.
- b. Identify the hormone whose level in the blood is responsible for the above disease.
- c. Which one of the following diets would you recommend to the affected patient?
 - i. High sugar and a low-fat diet.
 - ii. Low sugar and high protein diet.
 - iii. High Fat and low fibre diet.
 - iv. Low sugar and high fibre diet.
- d. Refer to Table A and suggest the value of the mean blood glucose level beyond which doctor's advice is necessary:
 - i. 80 mg/dL
 - ii. 115 mg/dL
 - iii. 50 mg/dL
 - iv. 80 mg/dL
5. The angle through which a ray of light turns on passing through a prism is called-
 - a. Angle of emergence.
 - b. Angle of incidence.
 - c. Angle of reflection.

d. Angle of deviation.

OR

The far point of a myopic person is 80cm in front of the eye. Which type of lens is required to correct the problem?

- a. Plane lens
 - b. Convex
 - c. Bifocal
 - d. Concave
6. The highest carbon content is found in which type of coal?
- a. Peat
 - b. Anthracite
 - c. Lignite
 - d. Bituminous
7. What does the tangent at any point on magnetic field lines indicate?
- a. direction of magnetic field
 - b. direction of the force
 - c. direction of current
 - d. direction of induced current
8. During the electrolysis of NaCl
- a. hydrogen gas at the anode and chlorine gas at the cathode
 - b. chlorine and hydrogen gas at the cathode
 - c. hydrogen and chlorine gas at the anode
 - d. chlorine gas is formed at the anode and hydrogen gas at the cathode.

OR

Tooth enamel is made up of

- a. calcium sulphate
 - b. calcium carbonate
 - c. calcium phosphate
 - d. calcium silicate
9. An agriculture / crop land is:
- a. A community of plants & animals only

- b. A natural ecosystem
- c. An artificial ecosystem
- d. A biome

10. Match the following with the correct response:

(1) Tree	(A) Producer
(2) Grasshopper	(B) Secondary consumer
(3) Frog	(C) Herbivore
(4) Snake	(D) Secondary carnivore

- a. 1-D, 2-A, 3-C, 4-B
- b. 1-C, 2-B, 3-D, 4-A
- c. 1-A, 2-C, 3-B, 4-D
- d. 1-B, 2-D, 3-A, 4-C

11. Which of the following statement is not a correct statement about the trends when going from left to right across the periodic table.

- a. The number of valence electrons increases
- b. The elements become less metallic in nature
- c. The oxides become more acidic
- d. The atoms lose their electrons more easily

12. Match the following with the correct response:

(1) Metal	(A) Acidic oxides
(2) Non-metal	(B) Neutral
(3) Amphoteric	(C) Both acidic and basic oxides
(4) Salts	(D) Basic oxides

- a. 1-D, 2-A, 3-C, 4-B
- b. 1-C, 2-B, 3-D, 4-A
- c. 1-A, 2-C, 3-B, 4-D
- d. 1-B, 2-D, 3-A, 4-C

13. **Assertion:** Hydrogenation is the process of converting oil into fat, called vegetable ghee.

Reason: Hydrogenation is carried out in the presence of a catalyst usually finely divided nickel.

- Both assertion and reason are CORRECT and reason is the CORRECT explanation of the assertion.
- Assertion is INCORRECT but, reason is CORRECT.
- Assertion is CORRECT but, reason is INCORRECT.
- Both assertion and reason are CORRECT but, reason is NOT THE CORRECT explanation of the assertion.

14. **Assertion:** When the length of a wire is doubled, then its resistance also gets doubled.

Reason: The resistance of a wire is directly proportional to its length.

- Assertion is INCORRECT but, reason is CORRECT.
- Both assertion and reason are CORRECT and reason is the CORRECT explanation of the assertion.
- Both assertion and reason are CORRECT but, reason is NOT THE CORRECT explanation of the assertion.
- Assertion is CORRECT but, reason is INCORRECT.

Section B

15. Why do acids not show acidic behaviour in the absence of water?

16. A compound 'X' used for drinking has $\text{pH} = 7$. Its acidified solution undergoes decomposition in presence of electricity to produce gases 'Y' and 'Z'. The volume of Y is double than Z. Y is highly combustible whereas Z is a supporter of combustion. Identify X, Y & Z and write the chemical reactions involved.

OR

What is the difference between the displacement and double displacement reactions? Write equations for these reactions.

17. An atom has electronic configuration 2, 8, 7.

(a) What is the atomic number of this element?

(b) To which of the following elements would it be chemically similar?
(Atomic numbers are given in parentheses.)

N(7), F(9), P(15), Ar(18)

18. What is role of skin, lungs and kidneys in the process of excretion in man?

OR

What will happen to a plant if its xylem is removed?

19. What is name of defect of eye due to loss of elasticity of eye-lens? How is it corrected?

20. Explain best-adapted individuals contribute maximum in gene pool.

21. What are the different kinds of neurons?

22. A circular metallic loop is kept above the wire AB as shown below:

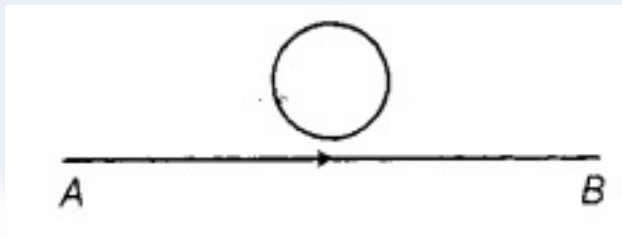

What is the direction of induced current produced in the loop, if the current flowing in the straight wire

- i. is steady, i.e. does not vary?
- ii. is increasing in magnitude?

Justify your answer in each case.

23. Draw the symbols of the following components that are used in the circuit diagram:

- i. Wires crossing without joining
- ii. Variable resistance or rheostat
- iii. A battery or a combination of cells

24. Light rays A and B fall on the component X and come out as C and D.

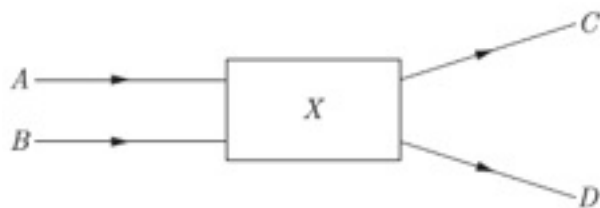

- i. Write the name of optical component.
- ii. An object is placed at the radius of curvature of a concave spherical mirror. Where does image is formed by the mirror?
- iii. What type of mirror is used in the construction of shaving glass? Why?

OR

An object 4.0 cm in size is placed 25.0 cm. in front of a concave mirror of focal length 15.0 cm. At what distance from the mirror should a screen be placed in order to obtain sharp image? Find the nature and the size of the image.

Section C

25. What are the various methods used for concentration of ore/ Ore dressing?
26. What are carboxylic acids? Give the common names, IUPAC names and structural formula of first four members of the homologous series.
27. Explain the nutrition process in an Amoeba with the help of a diagram.
28. a. Describe asexual reproduction in Amoeba.
b. How does sexual reproduction in plants takes place?

OR

With the help of a labelled diagram describe double fertilization in plants.

29. Current I flowing through a resistor results in dissipation of power P . By what percentage will the power dissipated in the resistor increase, if the current through the resistor is increased by 50 per cent? Justify your answer with the help of mathematical calculations.

30. One half of a convex lens of focal length 10 cm is covered with a black paper. Can such a lens produce an image of a complete object placed at a distance of 30 cm from the lens? Draw a ray diagram to justify your answer.

A 4 cm tall object is placed perpendicular to principal axis of a convex lens of focal length 20 cm. The distance of the object from the lens is 15 cm. Find the nature, position and the size of the image.

OR

An object 2 cm high is placed at a distance of 16 cm from a concave mirror which produce a real image 3 cm high.

(i) What is the focal length of the mirror?

(ii) Find the position of the image.



Vidya Champ

CBSE Class 10 Science
Sample Paper 05 (2019-20)

Answer
Section A

1. The required balanced reaction is given below: $C_2H_5OH + CH_3COOH$
Ethanol *Ethanoic acid*

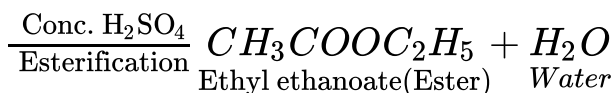

2. Metallic character decreases as you move across a period in the periodic table from left to right. This occurs as atoms more readily accept electrons to fill a valence shell than lose them to remove the unfilled shell.
3. i. **Non-renewable resources** are those found inside the earth, and they took millions of years to form.
ii. The five examples of non-renewable energy sources are fossil fuels, oil, natural gas, and coal and nuclear energy.
iii. Carbon is the main element in fossil fuels.
iv. Combustion of fossil fuel doesn't lead to the destruction of wildlife habitat.
4. a. Diabetes
b. (b) Insulin
c. (iv) low sugar high fibre diet
d. (i) 180mg/dL
5. (d) Angle of deviation.

Explanation: The angle of deviation through a triangular prism is defined as the angle between the incident ray and the emergent ray (angle D).

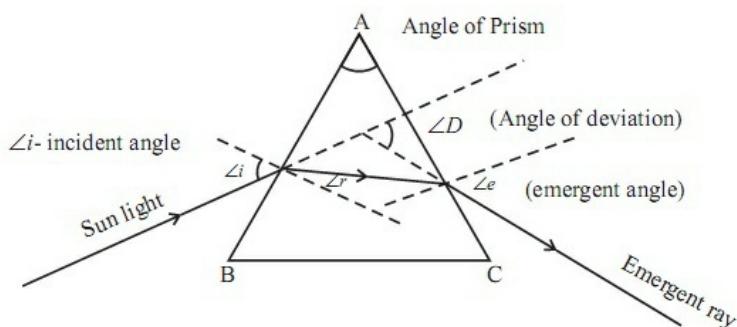

OR

(d) Concave

$$\frac{1}{f} = \frac{1}{v} - \frac{1}{u}$$

$$v = -80 \text{ cm}, u = \infty$$

$$\frac{1}{f} = \frac{1}{-80} - \frac{1}{\infty}$$

Explanation: $\frac{1}{f} = \frac{-1}{80} - 0$

$$\frac{1}{f} = \frac{-1}{80}$$

$$f = -80 \text{ cm}$$

$$P = \frac{100}{f} = \frac{100}{-80} = -1.25 \text{ D}$$

Concave lens of power 1.25 D will be used.

6. (b) Anthracite, **Explanation:** Anthracite is the highest rank of coal. Carbon content Anthracite more than 91.5%.

7. (a) direction of magnetic field **Explanation:** Tangent indicates the direction of the magnetic field. It just an alternative used when compass is not available

8. (d) chlorine gas is formed at the anode and hydrogen gas at the cathode.

Explanation: Chloride ions being negatively charged move towards the positively charged anode where they give away their electrons to form chlorine atoms which combine to form molecules while positively charged hydrogen ions move towards negatively charged cathode where they accept electrons from the cathode to form hydrogen atoms which combine to form hydrogen molecules.

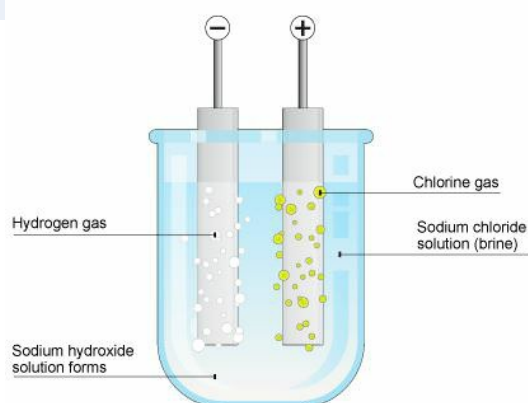

OR

(c) calcium phosphate, **Explanation:** Enamel is the hardest substance in the human body and contains the highest percentage of minerals, 96%, with water and organic material composing the rest. Tooth enamel is made of calcium phosphate.

9. (c) An artificial ecosystem

Explanation: An ecosystem may be natural or man-made (artificial). Forests, ponds and lakes are natural ecosystems while gardens and crop-fields are human-made (artificial) ecosystems.

10. (c) 1-A, 2-C, 3-B, 4-D

Explanation: A tree is a producer (autotroph). A grasshopper is a herbivore (primary consumer). A frog is secondary consumer.

(1) Tree	(A) Producer
(2) Grasshopper	(C) Herbivore
(3) Frog	(B) Secondary consumer
(4) Snake	(D) Secondary carnivore

11. (d) The atoms lose their electrons more easily

Explanation: On moving from left to right in a period, the electropositive character of element decreases i.e. it becomes difficult for elements to lose electrons and form positive ions.

12. (a) 1-D, 2-A, 3-C, 4-B

Explanation: Most metals form basic oxides. Non-metals form acidic oxides. Amphoteric substances like zinc and aluminium form basic oxides as well as acidic oxides. Most salts are neutral in nature.

13. (d) Both assertion and reason are CORRECT but, reason is NOT THE CORRECT explanation of the assertion. Explanation: Both assertion and reason are CORRECT but, reason is NOT THE CORRECT explanation of the assertion.

14. (b) Both assertion and reason are CORRECT and reason is the CORRECT explanation of the assertion. Explanation: Both assertion and reason are CORRECT and reason is the CORRECT explanation of the assertion.

Section B

15. The acid behavior of acid is due to the presence of hydrogen ions. The acids will not show its acidic behavior in the absence of water, this is because the acids produce hydrogen ions only in the presence of water.

16. We use water for drinking and being a neutral compound it has pH=7. So, **compound 'X' = Water (H₂O)** Acidified solution of water undergoes decomposition to form

hydrogen (H₂) and oxygen gas (O₂). Hydrogen gas formed is double in volume than oxygen gas and is highly combustible. Oxygen gas is a supporter of combustion. So, Y = H₂ gas ; Z = O₂ gas

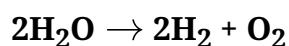

OR

Displacement reaction: The reaction in which an element displaces another element from a substance is called “displacement reaction.” In this reaction a more active element displaces less active element from solution of its compound. In displacement reaction one element displaces another element from its compound and takes its place therein.

Examples

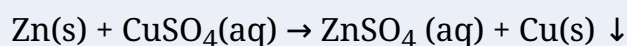
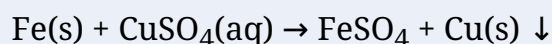

Double displacement reaction: The reaction in which the constituent atoms of the reaction interchange by the decomposition of the two reactants, to produce new compounds are called double displacement.

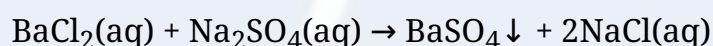
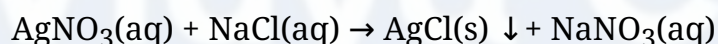

17. Chlorine has the electronic configuration 2, 8, 7.

(a) Atomic number of element is 17.

(b) F (9). (2, 7)

18. Skin- Skin excretes excess of salts and water in the form of sweat.

Lungs- Lungs expel carbondioxide during exhalation.

Kidney- Kidney removes nitrogenous waste such as urea through the formation of urine.

OR

The xylem tissue transports water and minerals from the roots to the leaves of a plant for photosynthesis. If xylem is removed, upward movement of water will stop leading

to wilting of leaves and ultimately leading to the death of the plant.

19. It is called presbyopia. It can be corrected by using two separate lenses, one for near vision and the other for distant vision.
20. Best Adapted individuals contribute maximum to gene pool: Generally, those individuals which are best adapted to the environment, i.e. which have adaptive (beneficial) mutations, have greater number of surviving young ones. The well-adapted individuals, on the whole, are healthier, and can find food and mate readily, and can better look after their offspring. Thus, the well-adapted individuals contribute most to the gene pool.
21. Kinds of neurons are
- a) Sensory neurons - convey impulses from receptors to the main nervous system.
 - b) Motor neurons - carry impulses from the main nervous system to an effector.
 - c) Relay neurons - connect sensory and motor centres.
22. i. The constant current flowing in the straight wire produces a constant magnetic field. Hence, no induced current is produced in the loop.
ii. Since current in the straight wire is changing, hence, induced current will be produced in clockwise direction.
23. The symbols of the following components that are used in the circuit diagram are as follows:

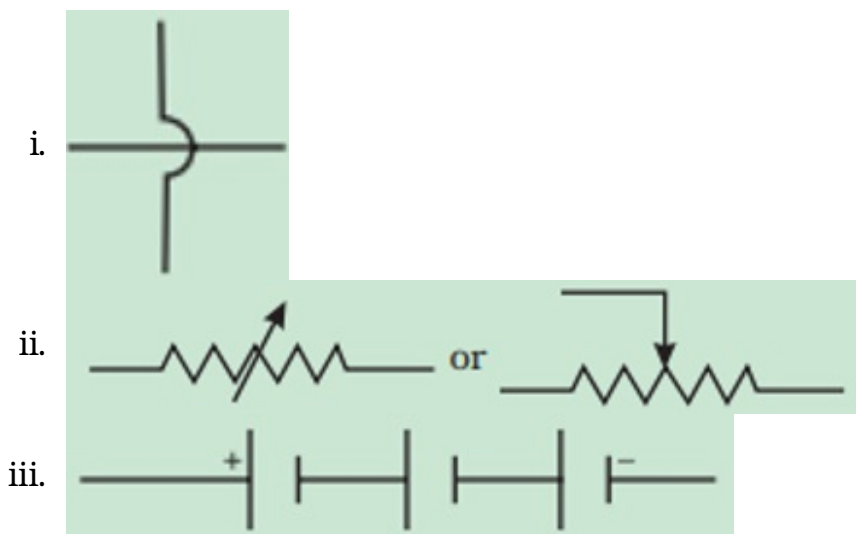

24. i. Concave lens.

- ii. The image formed at the centre of curvature of the mirror.
- iii. The concave mirror is used in the construction of shaving glass. Since concave mirrors magnify objects in focus and reflect real, almost 3-D images. Hence, used for shaving.

OR

$u = -25$ (u is always negative)

$v = ?$ $h_1 = 4 \text{ cm}$, $h_2 = ?$ $f = -15 \text{ cm}$

using $\frac{1}{f} = \frac{1}{v} + \frac{1}{u}$

$$\frac{1}{v} = \frac{1}{f} - \frac{1}{u} = \frac{1}{(-15)} - \frac{1}{(-25)}$$

$$\text{or } \frac{1}{v} = -\frac{1}{15} + \frac{1}{25} = \frac{-5 + 3}{75} = \frac{-2}{75}$$

$$\text{Or } v = \frac{-75}{2} = -37.5 \text{ cm}$$

The image is real and screen should be placed 37.5 cm from the mirror on the object side of the mirror.

$$\text{Now } m = \frac{h_2}{h_1} = -\frac{v}{u}$$

$$\text{or } m = \frac{h_2}{4} = \frac{(-37.5) \text{ cm}}{(-25) \text{ cm}} = -\frac{3}{2}$$

$$\text{or } h_2 = -\frac{3}{2} \times 4 = -6 \text{ cm}$$

The image is inverted and enlarged.

Section C

25. Concentration of Ore: The process of removal of unwanted impurities like sand, rocky material, earthy particles etc. from the ore is called ore concentration or ore dressing. The finely ground ore is concentrated by any of the following processes:
- i. Hydraulic washing: This method depends upon the difference in the densities of the ore particles and the impurities (gangue). The crushed and powdered ore is taken in large wooden tables with small obstacles. A stream of water is passed over the shaking table. The lighter impurities are washed away with the running stream of water while the heavier ore particles are left behind. This method of concentration is usually applicable to oxide ores.
 - ii. Froth floatation process: This method is used for the extraction of those metals in

which the ore particles are preferentially wetted by oil and gangue by water. In this method, the powdered ore is mixed with water containing small quantities of oil (pine oil or eucalyptus oil) in a large tank (Fig.), The water is agitated by blowing air violently when a froth (or foam) is formed. The froth carries the lighter ore particles along with it to the surface. The heavier impurities are left behind in water and these settle to the bottom. Since the ore particles float with the froth at the surface, this process is called froth floatation process. The froth at the surface is transferred into another tank. The froth is broken by adding some acid and ore particles are separated by filtration and dried. For example, the froth floatation process is commonly used for the sulphide ores of copper, zinc, lead et

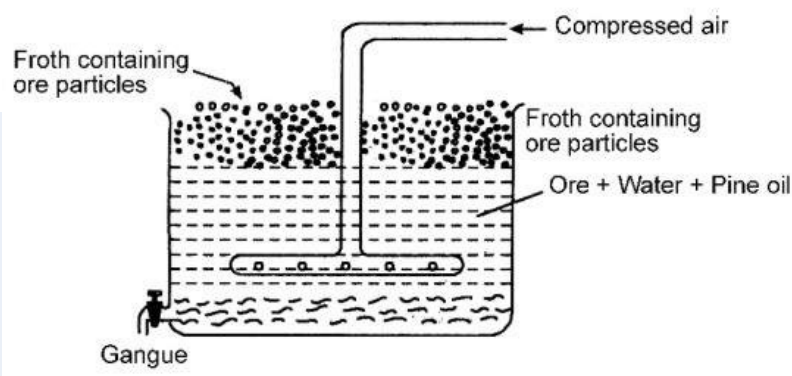

- iii. Magnetic separation: The ores which are attracted by a magnet can be separated from the non-magnetic impurities with the help of magnetic separation method. For example, this method is used for the concentration of haematite, an ore of iron. It consists of a leather belt moving over two rollers, one of which is magnetic in nature. This is shown in the figure. The powdered ore is dropped over the moving belt at one end. At the other end, the magnetic portion of the ore is attracted by the magnetic roller and falls nearer to the roller while the non-magnetic impurities fall farther off.

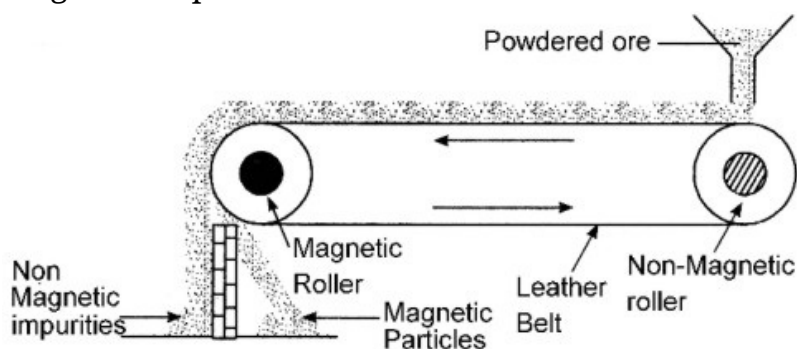

26. Carboxylic acids are organic compounds containing carboxylic acid group:
COOH or

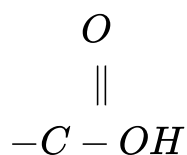

Their general formula is $C_nH_{2n+1}COOH$ or it may be written as $RCOOH$, where R is an alkyl group.

Members of the homologous series of carboxylic acids. The first four members of the homologous series of carboxylic acids are given ahead:

Molecular Formula	Structural Formula	Common name	IUPAC name
HCOOH	$H - \overset{\overset{O}{ }}{C} - OH$	Formic acid	Methanoic acid
CH ₃ COOH	$\begin{array}{c} H \\ \\ H - C - \overset{\overset{O}{ }}{C} - OH \\ \\ H \end{array}$	Acetic acid	Ethanoic acid
C ₂ H ₅ COOH	$\begin{array}{c} H & H & O \\ & & \\ H - C - C - C - OH \\ & & \\ H & H & \end{array}$	Propionic acid	Propanoic acid
C ₃ H ₇ COOH	$\begin{array}{c} H & H & H & O \\ & & & \\ H - C - C - C - C - OH \\ & & & \\ H & H & H & \end{array}$	n-Butyric acid	Butanoic acid

27. The mode of nutrition in Amoeba is holozoic.

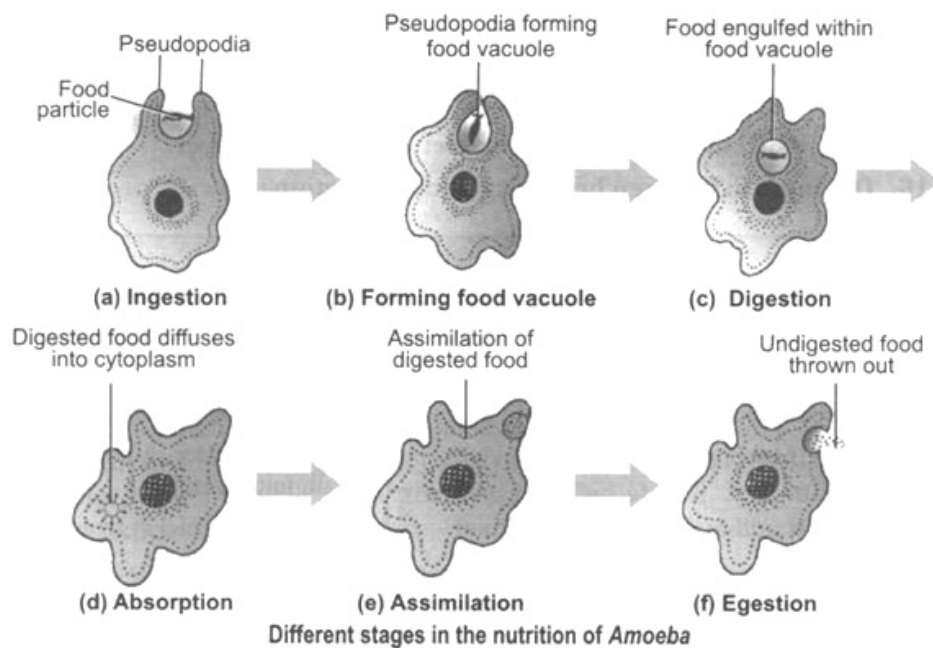

The various steps involved in the process of nutrition are:

- i. **Ingestion:** Amoeba ingests food with the help of its finger-like extensions, called pseudopodia. When Amoeba approaches a food particle, it forms pseudopodia around it and forms a food vacuole inside the Amoeba.
 - ii. **Digestion:** Various enzymes from the cytoplasm enter into the food vacuole and break them down into simple soluble molecules.
 - iii. **Absorption:** The simple soluble food is absorbed by cytoplasm of Amoeba from food vacuoles through the process of diffusion.
 - iv. **Assimilation:** Amoeba cell obtains energy from the absorbed food through respiration. This energy is utilised by Amoeba for its growth and repair of the body.
 - v. **Egestion:** When a considerable amount of undigested food gets collected inside Amoeba, its cell membrane ruptures and throws out the undigested food.
28. a. In Amoeba, asexual reproduction occurs by fission (binary and multiple). In Amoeba, nucleus first divides into two daughter nuclei by mitosis and then body along with the cytoplasm constricts from the middle, which gradually deepens and eventually divides into two individual parts, each part has one nucleus. Thus, two daughter Amoebae develop from one. This is called binary fission. In multiple fission, nucleus repeatedly divides to form a large number of nuclei, which reach at the periphery. Later cytoplasm gathers around each nucleus to form a daughter Amoeba. In this process, several individuals (equal to number of nuclei) develop

from a single Amoeba.

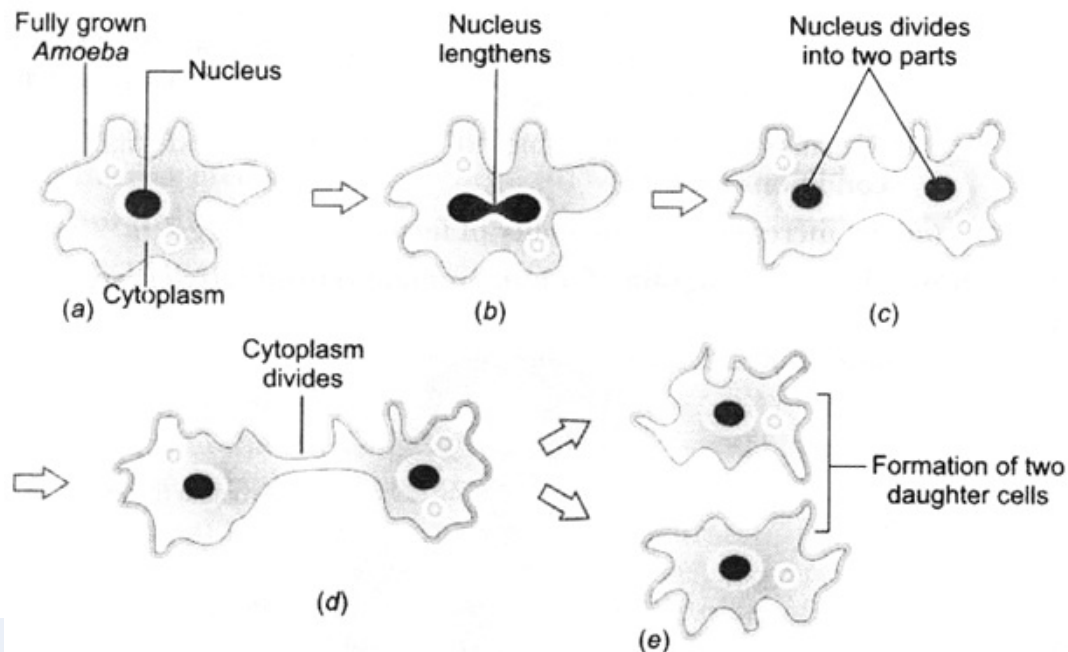

- b. Sexual reproduction in plants takes place in the following steps:
- The male reproductive organ 'stamen' makes the male gametes.
 - The female reproductive organ 'carpel' makes the female gametes.
 - The male gametes fertilise the female gametes.
 - The fertilised ovules grow and become seeds.
 - The seeds produce new plants under favourable conditions like presence of water, warmth, air, light, etc.

OR

Double fertilization: In Angiosperms both the male gametes are functional. Double fertilization is a process in which egg nucleus and secondary nucleus are fertilized at one time by two male gametic nuclei. The fusion of one male gamete nucleus (1N) with egg or oosphere (1N) is called syngamy and results in the formation of oospore (2N). The fusion of second male nucleus (1N) with secondary nucleus (2N) is called triple fusion which results in formation of primary endosperm nucleus (3N).

Significance.

- Double fertilization provides stimulus to endosperm mother cell for the formation of nutritive tissue named endosperm.
- It ensures continued supply of nourishment to the embryo that develops from zygote.

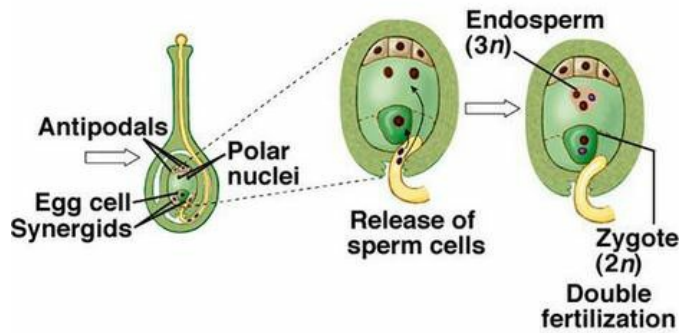

29. The power dissipated in the resistor will increase by 125 percent.

Justification using mathematical calculations.

$$P = I^2 R t$$

When I is increased by 50%, $I' = \frac{3}{2} I$.

$$\text{Hence, } P' = I'^2 R t = \left(\frac{3}{2} I\right)^2 R t$$

$$P' = \frac{9}{4} I^2 R t$$

$$\therefore \text{Increase in power dissipation} = \frac{9}{4} I^2 R t - I^2 R t = \frac{5}{4} I^2 R t$$

$$\therefore \text{Percentage increase} = \frac{\text{Increase}}{\text{Original}} \times 100\% = \frac{5}{4} \frac{I^2 R t}{I^2 R t} \times 100\% = 125\%$$

30. When a convex lens is covered half with black paper as shown in diagram, then image of full object will formed , but it will be of less intensity and brightness.

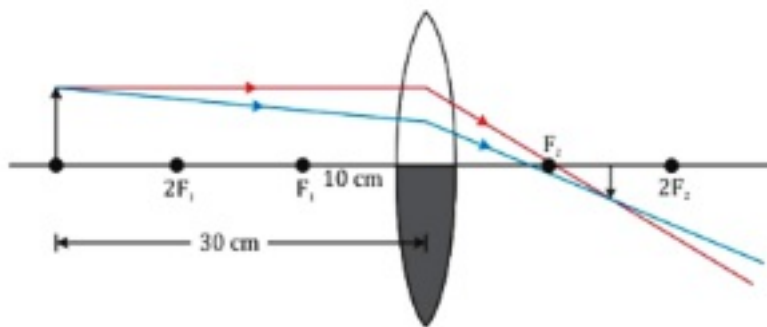

As $h_0 = 4$ cm, $f = 20$ cm and $u = -15$ cm

By lens formula,

$$\frac{1}{f} = \frac{1}{v} - \frac{1}{u}$$

$$\Rightarrow \frac{1}{v} = \frac{1}{f} + \frac{1}{u} = \frac{1}{20} + \frac{1}{(-15)} = \frac{15-20}{300} = \frac{-5}{300}$$

$$\therefore v = -60 \text{ cm}$$

As, magnification,

$$m = \frac{h_i}{h_0} = \frac{v}{u}$$

$$\Rightarrow h_i = h_0 \times \frac{v}{u} = 4 \times \frac{-60}{-15} = 16 \text{ cm}$$

Image formed is virtual, erect and magnified.

OR

Since the image formed is real, hence an inverted image is formed.

size of image, $h_2 = -3 \text{ cm}$, size of object $h_1 = +2 \text{ cm}$.

Magnification $m = \frac{h_2}{h_1} = \frac{-3}{2} = -1.5$. Also

$$m = \frac{-v}{u} \text{ or } v = -mu \dots\dots\dots (i)$$

Here $v = -16 \text{ cm}$ (u is always negative)

Substituting in (i), we have $v = -(-1.5)(-16) = -24 \text{ cm}$. or $v = -24 \text{ cm}$.

Image is formed 24 cm to the left of the mirror (Negative sign – Image is towards left of mirror)

To calculate focal length. Here $u = -16 \text{ cm}$, $v = -24 \text{ cm}$, $f = ?$

Using

$$\frac{1}{f} = \frac{1}{v} + \frac{1}{u} \text{ or } \frac{1}{f} = -\frac{1}{24} - \frac{1}{16} = \frac{-2-3}{48} = -\frac{5}{48} \text{ or } f = -\frac{48}{5} = -9.6 \text{ cm}$$

Negative focal length indicates that the mirror is concave.