

CBSE Class 10th Mathematics
Standard Sample Paper - 05

Maximum Marks:

Time Allowed: 3 hours

General Instructions:

- i. All the questions are compulsory.
- ii. The question paper consists of 40 questions divided into 4 sections A, B, C, and D.
- iii. Section A comprises of 20 questions of 1 mark each. Section B comprises of 6 questions of 2 marks each. Section C comprises of 8 questions of 3 marks each. Section D comprises of 6 questions of 4 marks each.
- iv. There is no overall choice. However, an internal choice has been provided in two questions of 1 mark each, two questions of 2 marks each, three questions of 3 marks each, and three questions of 4 marks each. You have to attempt only one of the alternatives in all such questions.
- v. Use of calculators is not permitted.

Section A

1. Every positive even integer is of the form ____ for some integer 'q'.
 - a. $2q + 1$
 - b. none of these
 - c. $2q - 1$
 - d. $2q$
2. The decimal expansion of number $\frac{441}{2^2 \times 5^3 \times 7}$ has
 - a. None of these
 - b. non-terminating and non-repeating decimal

-
- c. terminating decimal
- d. non-terminating repeating decimal
3. $Mode + \frac{3}{2}(Median - Mode) =$
- a. None of these
- b. Median
- c. Mean
- d. Mode
4. The sum of the roots of the quadratic equation $6x^2 - 13x - 5 = 0$ is
- a. $-\frac{5}{6}$
- b. $-\frac{13}{6}$
- c. $\frac{13}{6}$
- d. $\frac{5}{6}$
5. A circus artist is climbing a 20 m long rope, which is tightly stretched and tied from the top of a vertical pole to the ground. If the angle made by the rope with the ground level is 30° , then the height of the pole is
- a. 20 m
- b. $20\sqrt{3}$ m
- c. 10 m
- d. $10\sqrt{3}$ m
6. If $\sin \alpha = \frac{1}{\sqrt{2}}$ and $\tan \beta = 1$, then the value of $\cos(\alpha + \beta)$ is
- a. 3
- b. 1

c. 2

d. 0

7. $\frac{2 \tan 30^\circ}{1 + \tan^2 30^\circ} =$

a. $\cos 60^\circ$

b. None of these

c. $\tan 60^\circ$

d. $\sin 60^\circ$

8. A card is drawn from a pack of 52 cards at random. The probability of getting neither an ace nor a king card is

a. $\frac{4}{13}$

b. $\frac{8}{13}$

c. $\frac{2}{13}$

d. $\frac{11}{13}$

9. The area of the triangle with vertices $(a, b+c)$, $(b, c+a)$ and $(c, a+b)$ is

a. $a + b + c$

b. $a^2 + b^2 + c^2$

c. 0

d. $(a + b + c)^2$

10. The point on the x-axis which is equidistant from the points $(2, -5)$ and $(-2, 9)$ is

a. $(0, -7)$

b. $(-7, 0)$

c. $(0, 7)$

d. (7, 0)

11. Fill in the blanks:

Volume of the given figure is _____.

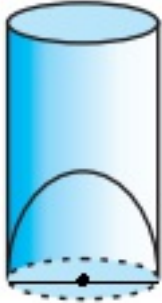

12. Fill in the blanks:

_____ is the point where $3x + 5$, intersects the x-axis.

OR

Fill in the blanks:

A quadratic polynomial whose zeros are α and β is given by $p(x) = \underline{\hspace{2cm}}$.

13. Fill in the blanks:

The _____ is the line drawn from the eye of an observer to the point in the object viewed by the observer.

14. Fill in the blanks:

-81 is the _____ term of the AP: 21, 18, 15,

15. Fill in the blanks:

A continuous piece of a circle is called an _____.

16. Find the HCF and LCM of 6 and 20 using fundamental theorem of arithmetic.

17. In figure, CP and CQ are tangents to a circle with centre O. ARB is another tangent touching the circle at R. If CP = 11 cm, and BC = 7 cm, then find the length of BR.

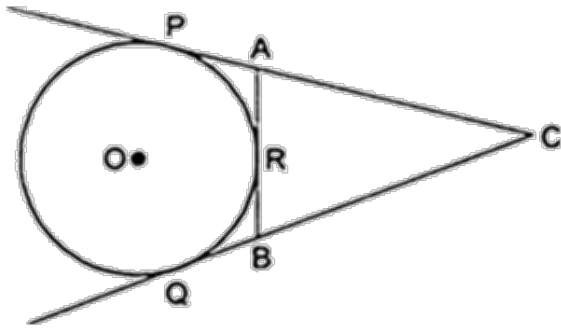

18. To draw a pair of tangents to a circle which are inclined to each other at an angle of 30° , it is required to draw tangents at end points of two radii of the circle, what will be the angle between them?
19. If the common difference of an A.P. is 3, then what is the value of $a_{20} - a_{15}$?

OR

Find the sum of each of the following APs: 9,7,5,3,... to 14 terms.

20. Determine whether the given quadratic equation has real roots. If so, find the roots.

$$x^2 + x + 2 = 0$$

Section B

21. A bag contains 3 red, 5 black and 7 white balls. A ball is drawn from the bag at random. Find the probability that the ball drawn is
- White
 - red
 - not black
 - red or white
22. Two circles touch each other externally at C. AB and CD are two common tangents. If D lies on AB such that $CD = 6$ cm, then find AB.
23. In Fig. (i) and (ii), $PQ \parallel BC$. Find QC in (i) and AQ in (ii).

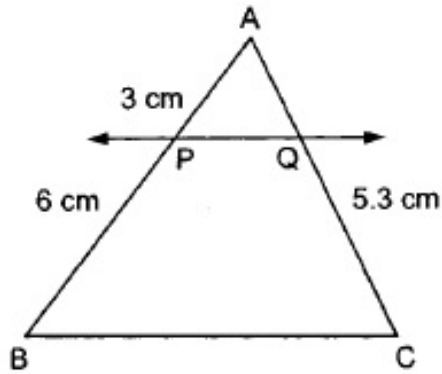
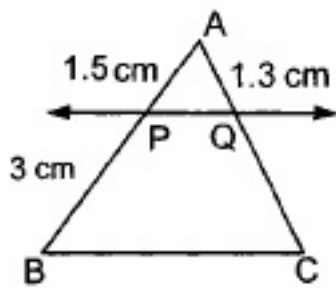

OR

In an equilateral triangle ABC, AD is drawn perpendicular to BC meeting BC in D. Prove that $AD^2 = 3BD^2$.

24. Two stations due south of a leaning tower which leans towards the north are at distances a and b from its foot. If α, β be the elevations of the top of the tower from these stations, prove that its inclination θ to the horizontal is given by

$$\cot \theta = \frac{b \cot \alpha - a \cot \beta}{b - a}$$

25. Find the least positive value of k for which the equation $x^2 + kx + 4 = 0$ has real roots.

OR

If the equation $mx^2 + 2x + m = 0$ has two equal roots, then find the values of m .

26. An 'ice-cream seller used to sell different kinds and different shapes of ice-cream like rectangular shaped with one end hemispherical, cone-shaped and rectangular brick, etc. One day a child came to his shop and purchased an ice-cream which has the following shape: ice-cream cone as the union of a right circular cone and a hemisphere that has the same (circular) base as the cone. The height of the cone is 9 cm and the radius of its base is 2.5 cm.

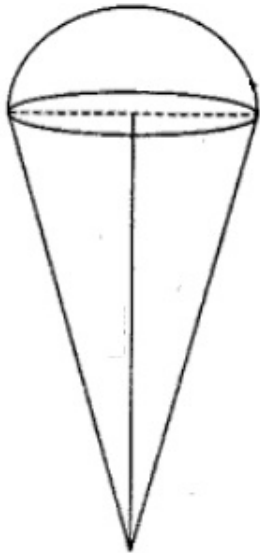

By reading the above-given information, find the following:

- i. The volume of the ice-cream without hemispherical end.
- ii. The volume of the ice-cream with a hemispherical end.

Section C

27. Show that one and only one out of n , $(n + 2)$ or $(n + 4)$ is divisible by 3, where $n \in \mathbb{N}$.

OR

Prove that $\sqrt{6}$ is irrational.

28. The line segment joining the points $(3, -4)$ and $(1, 2)$ is trisected at the points P and Q. If the coordinates of P and Q are $(p, -2)$ and $(\frac{5}{3}, q)$ respectively. Find the values of p and q.

29. Find the angles of a cyclic quadrilateral ABCD in which $\angle A = (4x + 20)^\circ$, $\angle B = (3x - 5)^\circ$, $\angle C = (4y)^\circ$ and $\angle D = (7y + 5)^\circ$.

OR

Solve graphically the system of linear equations $x + 2y = 3$, $4x + 3y = 2$.

30. Find the zeroes of the polynomial $7y^2 - \frac{11}{3}y - \frac{2}{3}$ by factorisation method and verify the relationship between the zeroes and coefficient of the polynomials.

31. If the 10th term of an AP is 52 and 17th term is 20 more than its 13th term, find the AP.

32. If $\tan \theta = \frac{1}{\sqrt{2}}$, find the value of $\frac{\cos \text{ec}^2 \theta - \sec^2 \theta}{\cos \text{ec}^2 \theta + \cot^2 \theta}$.

OR

Show that $n(m^2 - 1) = 2m$ if $\sin \theta + \cos \theta = m$ and $\sec \theta + \text{cosec} \theta = n$

33. In fig., find the area of the shaded region [Use $\pi = 3.14$]

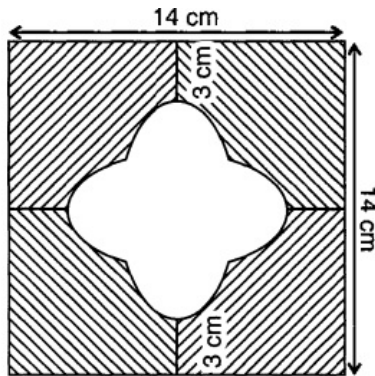

34. Cards marked with the numbers 2 to 101 are placed in a box and mixed thoroughly. One card is drawn from this box. Find the probability that the number on the card is:
- an even number
 - a number less than 14
 - a number which is a perfect square
 - a prime number less than 20.

Section D

35. Draw a pair of tangents to a circle of radius 5 cm which are inclined to each other at an angle of 60° .

OR

Construct a $\triangle ABC$ in which $AB = 5$ cm. $\angle B = 60^\circ$ altitude $CD = 3$ cm. Construct a $\triangle AQR$ similar to $\triangle ABC$ such that side of $\triangle AQR$ is 1.5 times that of the corresponding sides of $\triangle ACB$.

36. In Fig. if $\triangle EDC \sim \triangle EBA$, $\angle BEC = 115^\circ$ and $\angle EDC = 70^\circ$. Find $\angle DEC$, $\angle DCE$, $\angle EAB$, $\angle AEB$ and $\angle EBA$.
37. Find the values of k for which the system of equations $kx - y = 2$, $6x - 2y = 3$ has

- i. a unique solution,
- ii. no solution.
- iii. Is there a value of k for which the given system has infinitely many solutions?

OR

Solve the following system of equations graphically:

$$2x - 3y + 13 = 0 \text{ and } 3x - 2y + 12 = 0.$$

38. A solid metallic right circular cone 20 cm high with vertical angle 60° is cut into two parts at the middle point of its height by a plane parallel to the base. If the frustum so obtained be drawn into a wire of diameter $\frac{1}{16}$ cm, find the length of the wire.

OR

The height of a cone is 30 cm. From its topside a small cone is cut by a plane parallel to its base. If volume of smaller cone is $\frac{1}{27}$ of the cone then at what height it is cut from the base?

39. A statue 1.46m tall, stands on the top of a pedestal. From a point on the ground, the angle of elevation of the top of the statue is 60° and from the same point, the angle of elevation of the top of the pedestal is 45° . Find the height of the pedestal. [Use $\sqrt{3} = 1.73$.]
40. Find the mean, median and mode of the following data:

| Class | 0 - 10 | 10 - 20 | 20 - 30 | 30 - 40 | 40 - 50 | 50 - 60 | 60 - 70 |
|-----------|--------|---------|---------|---------|---------|---------|---------|
| Frequency | 6 | 8 | 10 | 15 | 5 | 4 | 2 |

CBSE Class 10th Mathematics
Standard Sample Paper - 05

Solution

Section A

1. (d) $2q$

Explanation:

Let a be any positive integer and $b=2$

Then by applying Euclid's Division Lemma, we have,

$$a = 2q + r \text{ where } 0 \leq r < 2 \text{ } r = 0 \text{ or } 1$$

Therefore, $a = 2q$ or $2q + 1$

Thus, it is clear that $a = 2q$

i.e., a is an even integer in the form of $2q$

2. (d) non-terminating repeating decimal

Explanation:

The decimal expansion of number $\frac{441}{2^2 \times 5^3 \times 7}$ has non-terminating repeating decimal because its denominator has the factor 7 other than 2 or 5.

3. (c) Mean

Explanation:

$$3 \text{ Median} = 2 \text{ Mean} + \text{Mode}$$

$$\Rightarrow 3 \text{ Median} - \text{Mode} = 2 \text{ Mean}$$

$$\Rightarrow \text{Mean} = \frac{3}{2} \text{ Median} - \frac{\text{Mode}}{2}$$

$$\Rightarrow \text{Mode} + \frac{3}{2} \text{ Median} - \frac{\text{Mode}}{2} - \text{Mode} = \text{Mean}$$

$$\Rightarrow \text{Mode} + \frac{3}{2} (\text{Median} - \text{Mode}) = \text{Mean}$$

4. (c) $\frac{13}{6}$

Explanation:

$$\text{Given: } 6x^2 - 13x - 5 = 0$$

$$\Rightarrow x^2 - \left(\frac{13}{6}\right)x + \left(\frac{-5}{6}\right) = 0$$

Comparing with $x^2 - (\alpha + \beta)x + \alpha\beta = 0$,
we get The sum of roots = $\frac{13}{6}$

5. (c) 10 m

Explanation:

In right triangle ABC,

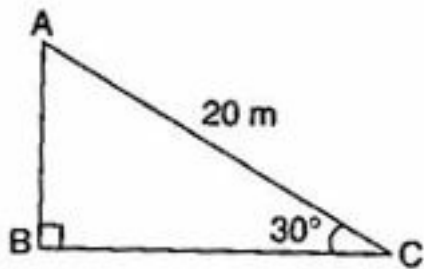

$$\sin 30^\circ = \frac{AB}{AC}$$

$$\Rightarrow \frac{1}{2} = \frac{AB}{20} \Rightarrow AB = 10 \text{ m}$$

Hence, the height of the pole is 10 m.

6. (d) 0

Explanation:

$$\text{Given: } \sin \alpha = \frac{1}{\sqrt{2}}$$

$$\Rightarrow \sin \alpha = \sin 45^\circ$$

$$\Rightarrow \alpha = 45^\circ$$

$$\text{And } \tan \beta = 1$$

$$\Rightarrow \tan \beta = \tan 45^\circ$$

$$\Rightarrow \beta = 45^\circ$$

$$\therefore \cos(\alpha + \beta) = \cos(45^\circ + 45^\circ) = \cos 90^\circ = 0$$

7. (d) $\sin 60^\circ$

Explanation:

$$\text{Given: } \frac{2 \tan 30^\circ}{1 + \tan^2 30^\circ}$$

$$= \frac{2 \times \frac{1}{\sqrt{3}}}{1 + \left(\frac{1}{\sqrt{3}}\right)^2}$$

$$\begin{aligned}
&= \frac{2}{\sqrt{3}\left(\frac{3+1}{3}\right)} \\
&= \frac{6}{4\sqrt{3}} = \frac{3}{2\sqrt{3}} \\
&= \frac{\sqrt{3}}{2} \\
&= \sin 60^\circ
\end{aligned}$$

8. (d) $\frac{11}{13}$

Explanation:

Number of Total outcomes = 52

Number of aces and Number of kings = 4 + 4 = 8

Number of cards except ace and king = 52 - 8 = 44

Required Probability = $\frac{44}{52} = \frac{11}{13}$

9. (c) 0

Explanation:

Given: Vertices of a triangle ABC, A(a, b+c), B(b, c+a) and C(c, a+b)

$$\begin{aligned}
\therefore \text{ar}(\Delta ABC) &= \frac{1}{2} |x_1(y_2 - y_3) + x_2(y_3 - y_1) + x_3(y_1 - y_2)| \\
&= \frac{1}{2} |a(c + a - a - b) + b(a + b - b - c) + c(b + c - c - a)| \\
&= \frac{1}{2} |a(c - b) + b(a - c) + c(b - a)| \\
&= \frac{1}{2} |ac - ab + ab - bc + bc - ac| \\
&= \frac{1}{2} \times 0 = 0 \text{ sq. units}
\end{aligned}$$

Also, therefore, the three given points are collinear.

10. (b) (-7, 0)

Explanation:

Let A(2, -5) and B(-2, 9).

Since point is on x-axis C(x, 0).

$$\begin{aligned}
\therefore AC^2 &= BC^2 \\
\Rightarrow (2 - x)^2 + (-5 - 0)^2 &= (-2 - x)^2 + (9 - 0)^2 \\
\Rightarrow 4 + x^2 - 4x + 25 &= 4 + x^2 + 4x + 81 \\
\Rightarrow -8x &= 56 \\
\Rightarrow x &= -7
\end{aligned}$$

Therefore, the point on x -axis is $(-7, 0)$.

11. $\pi r^2 h - \frac{2}{3} \pi r^3$

12. $\frac{-5}{3}, 0$

OR

$$x^2 - (\alpha + \beta)x + \alpha\beta$$

13. line of sight

14. 35th

15. arc

16. $6 = 2 \times 3$

$$20 = 2^2 \times 5$$

$$\therefore \text{HCF} = 2$$

$$\text{and LCM} = 2^2 \times 3 \times 5 = 60$$

17.

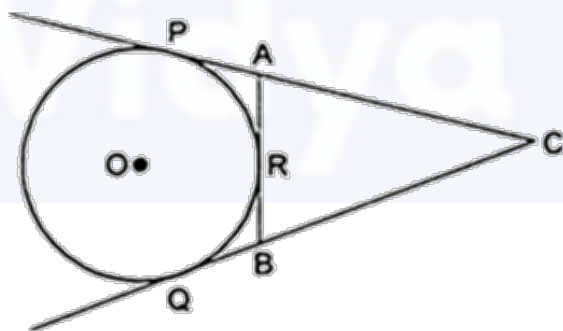

Since, $CP = CQ = 11\text{cm}$ [Length of the two tangents from same external point]

$$CQ = CB + BQ$$

$$\text{But, } BQ = BR$$

$$11 = 7 + BR$$

$$\Rightarrow BR = 4\text{ cm}$$

18. We know, tangent and radius of a circle are perpendicular to each other at point of contact

$$\therefore \text{Angle between the radii} = 360^\circ - 90^\circ - 90^\circ - 30^\circ = 150^\circ$$

19. Let the first term of the AP be a .

Given, common difference $(d) = 3$

$$a_n = a + (n - 1)d$$

Now,

$$a_{20} - a_{15} = [a + (20 - 1)d] - [a + (15 - 1)d]$$

$$= 19d - 14d$$

$$= 5d$$

$$= 5 \times 3$$

$$= 15.$$

OR

Here, $a = 9$, $d = 7 - 9 = -2$ and $n = 14$

Now, $S_n = \frac{n}{2} [2a + (n-1)d]$

$$\therefore S_{14} = \frac{14}{2} [2 \times 9 + (14 - 1)(-2)]$$

$$= 7[18 - 26]$$

$$= 7 \times (-8)$$

$$= -56$$

20. We have equation

$$x^2 + x + 2 = 0$$

By comparing with $ax^2 + bx + c = 0$ we get,

$$a = 1, b = 1 \text{ and } c = 2$$

For nature of roots we have to find discriminant

$$\therefore D = b^2 - 4ac$$

$$= (1)^2 - 4 \times 1 \times 2$$

$$= 1 - 8$$

$$= -7 < 0$$

$$\therefore D < 0$$

So, the given equation has no real roots.

Section B

21. Total number of balls $3+5+7=15$

Hence total outcomes =15

$$\text{Probability of the event} = \frac{\text{Number of favourable outcomes}}{\text{Total number of possible outcomes}}$$

i. (Total white ball=7

$$P(\text{white ball}) = \frac{7}{15}$$

ii. Total red balls=3

$$P(\text{red ball}) = \frac{3}{15} = \frac{1}{5}$$

iii. $P(\text{not Black}) = 1 - P(\text{Black}) = 1 - \frac{n\{\text{black}\}}{n\{\text{total}\}} = 1 - \frac{5}{15} = \frac{10}{15} = \frac{2}{3}$

iv. $P(\text{red or white}) = P(\text{red}) + P(\text{white}) = \frac{7}{15} + \frac{3}{15} = \frac{10}{15} = \frac{2}{3}$

22.

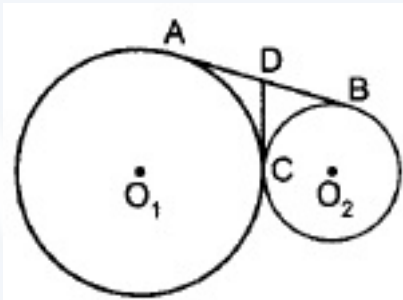

$AD = CD$ [Tangents drawn from an exterior point are equal]

$$\therefore AD = 6\text{cm}$$

Also $DB = CD$ [Tangents drawn from an exterior point are equal]

$$\therefore DB = 6\text{cm}$$

$$\Rightarrow AB = 6 + 6 = 12\text{cm}.$$

23. According to question

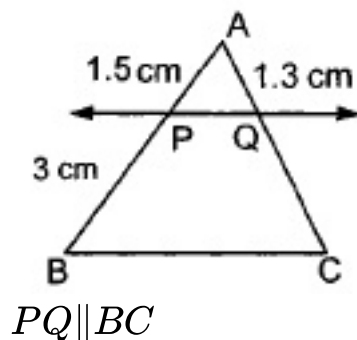

Therefore, by basic proportionality theorem, we have

$$\frac{AP}{PB} = \frac{AQ}{QC}$$
$$\Rightarrow \frac{1.5}{3} = \frac{1.3}{QC}$$

$$\Rightarrow \frac{1}{2} = \frac{1.3}{QC}$$

$$\Rightarrow QC = 2.6 \text{ cm}$$

In Fig. (ii)

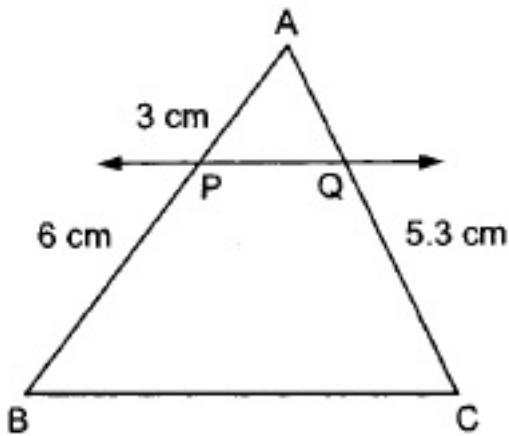

it is given that $PQ \parallel BC$.

Therefore, by basic proportionality theorem, we have

$$\frac{AP}{PB} = \frac{AQ}{QC}$$
$$\Rightarrow \frac{3}{6} = \frac{AQ}{5.3}$$
$$\Rightarrow \frac{1}{2} = \frac{AQ}{5.3}$$

$$\Rightarrow AQ = \frac{5.3}{2} = 2.65 \text{ cm}$$

Hence $QC = 2.6 \text{ cm}$ and $AQ = 2.65 \text{ cm}$ respectively

OR

According to the question, $\triangle ABC$ is an equilateral triangle.

In $\triangle ABD$, using Pythagoras theorem,

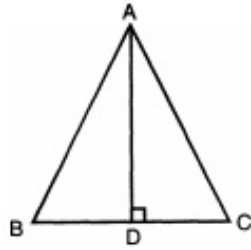

$$\Rightarrow AB^2 = AD^2 + BD^2$$

$$\Rightarrow BC^2 = AD^2 + BD^2, \text{ (as } AB = BC = CA)$$

$$\Rightarrow (2 BD)^2 = AD^2 + BD^2, \text{ (perpendicular is the median in an equilateral triangle)}$$

$$\Rightarrow 4BD^2 - BD^2 = AD^2$$

$$\therefore 3BD^2 = AD^2$$

24. Let AB be the leaning tower and let C and D be two given stations at distances a and b respectively from the foot A of the tower.

Let AE = x and BE = h

In $\triangle AEB$, we have

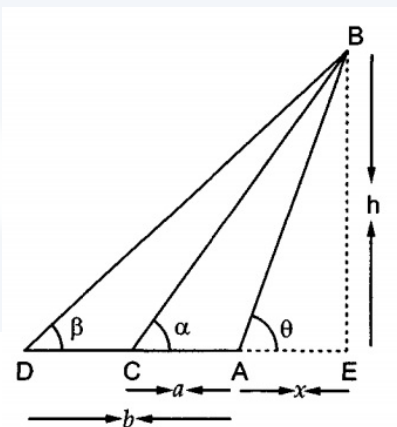

$$\tan \theta = \frac{BE}{AE}$$

$$\Rightarrow \tan \theta = \frac{h}{x}$$

$$\Rightarrow x = h \cot \theta \dots\dots(i)$$

In $\triangle CEB$, we have

$$\tan \alpha = \frac{BE}{CE}$$

$$\Rightarrow \tan \alpha = \frac{h}{a+x}$$

$$\Rightarrow a + x = h \cot \alpha$$

$$\Rightarrow x = h \cot \alpha - a \dots\dots(ii)$$

In $\triangle DEB$, we have

$$\tan \beta = \frac{BE}{DE}$$

$$\begin{aligned} \Rightarrow \tan \beta &= \frac{h}{b+x} \\ \Rightarrow b+x &= h \cot \beta \\ \Rightarrow x &= h \cot \beta - b \dots\dots\dots(\text{iii}) \end{aligned}$$

On equating the values of x obtained from equations (i) and (ii), we have

$$\begin{aligned} h \cot \theta &= h \cot \alpha - a \\ \Rightarrow h(\cot \alpha - \cot \theta) &= a \\ \Rightarrow h &= \frac{a}{\cot \alpha - \cot \theta} \dots\dots\dots(\text{iv}) \end{aligned}$$

On equating the values of x obtained from equations (i) and (iii), we get

$$\begin{aligned} h \cot \theta &= h \cot \beta - b \\ \Rightarrow h(\cot \beta - \cot \theta) &= b \\ \Rightarrow h &= \frac{b}{\cot \beta - \cot \theta} \dots\dots\dots(\text{v}) \end{aligned}$$

Equating the values of h from equations (iv) and (v), we get

$$\begin{aligned} \frac{a}{\cot \alpha - \cot \theta} &= \frac{b}{\cot \beta - \cot \theta} \\ \Rightarrow a(\cot \beta - \cot \theta) &= b(\cot \alpha - \cot \theta) \\ \Rightarrow (b-a)\cot \theta &= b \cot \alpha - a \cot \beta \\ \Rightarrow \cot \theta &= \frac{b \cot \alpha - a \cot \beta}{b-a} \end{aligned}$$

25. We have,

$$x^2 + kx + 4 = 0$$

Here, $a = 1$, $b = k$ and $c = 4$

$$\therefore D = b^2 - 4ac$$

$$= (k)^2 - 4 \times 1 \times 4$$

$$= k^2 - 16$$

$$\Rightarrow D = k^2 - 16$$

The given equation will have real roots, if

$$D \geq 0$$

$$\Rightarrow k^2 - 16 \geq 0$$

$$\Rightarrow k^2 - (4)^2 \geq 0$$

$$\Rightarrow k \leq -4 \text{ or } k \geq 4 \quad [\because x^2 - a^2 \geq 0 \Rightarrow x \leq -a \text{ or, } x \geq a]$$

$$\therefore k \geq 4$$

$\therefore k = 4$ is the least positive value for which the given equation has real roots

OR

We have the following equation,

$$mx^2 + 2x + m = 0$$

Here, $a = m$, $b = 2$ and $c = m$

Now, $D = 0$

$$\Rightarrow b^2 - 4ac = 0$$

$$\Rightarrow (2)^2 - 4(m)(m) = 0$$

$$\Rightarrow 4 - 4m^2 = 0$$

$$\Rightarrow 4m^2 = 4$$

$$\Rightarrow m^2 = \frac{4}{4}$$

$$\Rightarrow m^2 = 1$$

$$\Rightarrow m = \sqrt{1} \Rightarrow m = \pm 1$$

Therefore, $m = -1$ and $m = 1$

26. For cone, Radius of the base (r)

$$= 2.5\text{cm} = \frac{5}{2}\text{cm}$$

Height (h) = 9 cm

$$\therefore \text{Volume} = \frac{1}{3}\pi r^2 h$$

$$= \frac{1}{3} \times \frac{22}{7} \times \frac{5}{2} \times \frac{5}{2} \times 9$$

$$= \frac{825}{14}\text{cm}^3$$

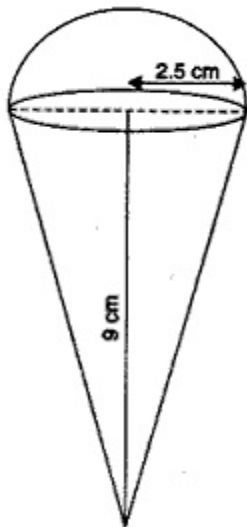

For hemisphere,

$$\text{Radius (r)} = 2.5\text{cm} = \frac{5}{2}\text{cm}$$

$$\therefore \text{Volume} = \frac{2}{3}\pi r^3$$

$$= \frac{2}{3} \times \frac{22}{7} \times \frac{5}{2} \times \frac{5}{2} \times \frac{5}{2} = \frac{1375}{42}\text{cm}^3$$

i. The volume of the ice-cream without hemispherical end = Volume of the cone
 $= \frac{825}{14}\text{cm}^3$

ii. Volume of the ice-cream with hemispherical end = Volume of the cone + Volume of the hemisphere

$$= \frac{825}{14} + \frac{1375}{42} = \frac{2475+1375}{42}$$

$$= \frac{3850}{42} = \frac{275}{3} = 91\frac{2}{3}\text{cm}^3$$

Section C

27. Let the number be $(3q + r)$

$$n = 3q + r \quad 0 \leq r < 3$$

or $3q, 3q + 1, 3q + 2$

If $n = 3q$ then, numbers are $3q, (3q + 1), (3q + 2)$

$3q$ is divisible by 3.

If $n = 3q + 1$ then, numbers are $(3q + 1), (3q + 3), (3q + 4)$

$(3q + 3)$ is divisible by 3.

If $n = 3q + 2$ then, numbers are $(3q + 2), (3q + 4), (3q + 6)$

$(3q + 6)$ is divisible by 3.

\therefore out of $n, (n + 2)$ and $(n + 4)$ only one is divisible by 3.

OR

If possible, let $\sqrt{6}$ be rational and let its simplest form be $\frac{a}{b}$ then, a and b are integers having no common factor other than 1, and $b \neq 0$.

$$\text{Now, } \sqrt{6} = \frac{a}{b}$$

$$\Rightarrow 6 = \frac{a^2}{b^2} \text{ [on squaring both sides]}$$

$$\Rightarrow 6b^2 = a^2 \text{(i)}$$

$$\Rightarrow 6 \text{ divides } a^2 \text{ [}\therefore 6 \text{ divides } 6b^2\text{]}$$

$$\Rightarrow 6 \text{ divides } a$$

Let $a = 6c$ for some integer c

putting $a = 6c$ in (i), we get

$$a^2 = 36c^2$$

$$6b^2 = 36c^2 \quad [6b^2 = a^2]$$

$$\Rightarrow b^2 = 6c^2$$

$$\Rightarrow 6 \text{ divides } b^2 \quad [\because 6 \text{ divides } 6c^2]$$

$$\Rightarrow 6 \text{ divides } b \quad [\because 6 \text{ divides } b^2 = 6 \text{ divides } b]$$

Thus, 6 is a common factor of a and b

But, this contradicts the fact that a and b have no common factor other than 1

The contradiction arises by assuming that $\sqrt{6}$ is rational.

Hence $\sqrt{6}$ is irrational.

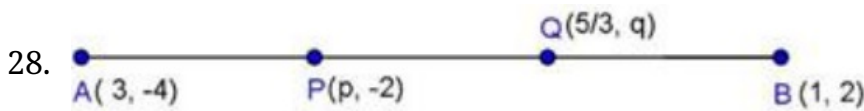

We have $P(p, -2)$ and $Q\left(\frac{5}{3}, q\right)$ are the points of trisection of the line segment joining $A(3, -4)$ and $B(1, 2)$

We know $AP : PB = 1 : 2$

By section formula $\left[\frac{mx_2 + nx_1}{m+n}, \frac{my_2 + ny_1}{m+n} \right]$ coordinates of P are

$$\left(\frac{1 \times 1 + 2 \times 3}{1+2}, \frac{1 \times 2 + 2 \times (-4)}{1+2} \right)$$

$$= \left(\frac{7}{3}, -2 \right)$$

$$\text{Hence, } P = \frac{7}{3}$$

Again we know that $AQ : QB = 2 : 1$

Therefore, Coordinates of Q are (using section formula)

$$\left(\frac{2 \times 1 + 1 \times 3}{2+1}, \frac{2 \times 2 + 1 \times (-4)}{2+1} \right)$$

$$= \left(\frac{5}{3}, 0 \right)$$

$$\text{Hence, } q = 0$$

Therefore, value of p and q is $\frac{7}{3}$ and 0 respectively.

29. It is given that angles of a cyclic quadrilateral $ABCD$ are given by:

$$\angle A = (4x + 20)^\circ,$$

$$\angle B = (3x - 5)^\circ,$$

$$\angle C = (4y)^\circ$$

$$\text{and } \angle D = (7y + 5)^\circ.$$

We know that the opposite angles of a cyclic quadrilateral are supplementary.

$$\angle A + \angle C = 180^\circ$$

$$4x + 20^\circ + 4y = 180^\circ$$

$$4x + 4y - 160^\circ = 0 \dots (1)$$

And $\angle B + \angle D = 180^\circ$

$$3x - 5 + 7y + 5 = 180^\circ$$

$$3x + 7y - 180^\circ = 0 \dots (2)$$

By elimination method,

Step 1: Multiply equation (1) by 3 and equation (2) by 4 to make the coefficients of x equal.

Then, we get the equations as:

$$12x + 12y = 480 \dots (3)$$

$$12x + 16y = 540 \dots (4)$$

Step 2: Subtract equation (4) from equation (3),

$$(12x - 12x) + (16y - 12y) = 540 - 480$$

$$\Rightarrow 4y = 60$$

$$y = 15$$

Step 3: Substitute value of y in (1),

$$4x + 4(15) - 160 = 0$$

$$\Rightarrow x = 25$$

Hence, the angles of ABCD are

$$\angle A = 120^\circ, \angle B = 70^\circ,$$

$$\angle C = 60^\circ \text{ and } \angle D = 110^\circ.$$

OR

On a graph paper, draw a horizontal line X'OX and a vertical line YOY' as the x-axis and the y-axis respectively.

Graph of $x + 2y = 3$

$$x + 2y = 3$$

$$\Rightarrow 2y = (3 - x)$$

$$\Rightarrow y = \frac{(3-x)}{2} \dots\dots(i)$$

Table for the equation $x + 2y = 3$.

| | | | |
|----------|----|----|---|
| x | -3 | -1 | 1 |
| y | 3 | 2 | 1 |

Now, plot the points $A(-3, 3)$, $B(-1, 2)$ and $C(1, 1)$ on the graph paper.

Join AB and BC to get the graph line ABC. Extend it on both ways.

Thus, the line ABC is the graph of $x + 2y = 3$.

$$4x + 3y = 2 \Rightarrow 3y = (2 - 4x)$$

$$\Rightarrow y = \frac{(2-4x)}{3} \dots\dots(ii)$$

Table for the equation $4x + 3y = 2$.

| | | | |
|----------|----|----|----|
| x | -4 | -1 | 2 |
| y | 6 | 2 | -2 |

Now, on the same graph paper as above, plot the points $P(-4, 6)$ and $Q(2, -2)$. The point $B(-1, 2)$ has already been plotted. Join PB and BQ to get the line PBQ. Extend it on both ways.

Thus, the line PBQ is the graph of $4x + 3y = 2$.

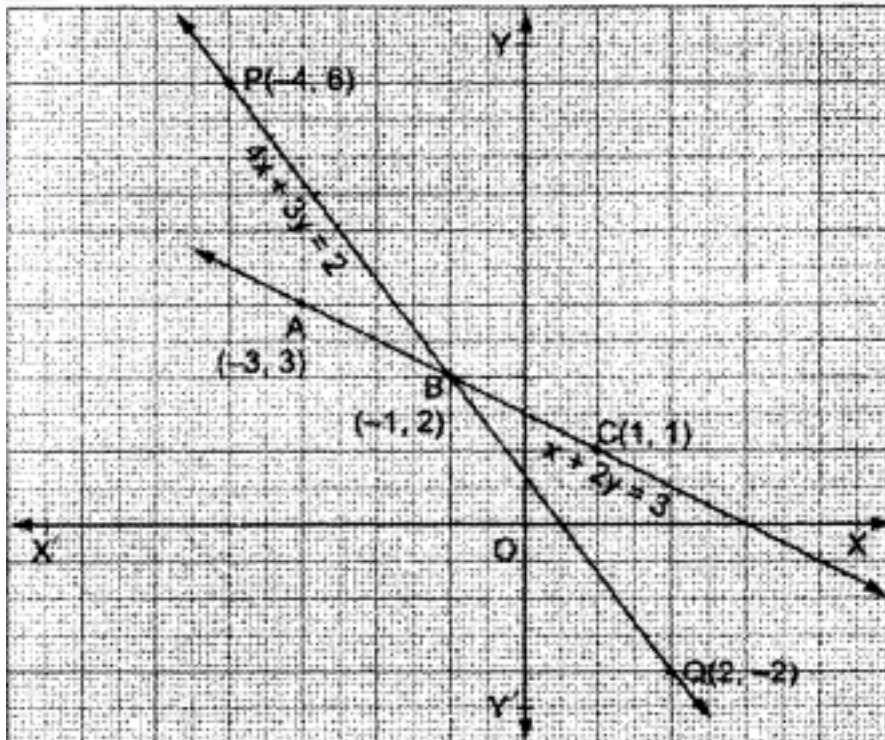

The two graph lines intersect at the point $B(-1, 2)$.

$\therefore x = -1$ and $y = 2$ is the solution of the given system of equations.

$$\begin{aligned}
30. \quad & 7y^2 - \frac{11}{3}y - \frac{2}{3} \\
& = \frac{1}{3}(21y^2 - 11y - 2) \\
& = \frac{1}{3}(21y^2 - 14y + 3y - 2) \\
& = \frac{1}{3}[7y(3y - 2) + 1(3y - 2)] \\
& = \frac{1}{3}(3y - 2)(7y + 1) \\
& \Rightarrow y = \frac{2}{3}, \frac{-1}{7} \text{ are zeroes of the polynomial.}
\end{aligned}$$

If Given polynomial is $7y^2 - \frac{11}{3}y - \frac{2}{3}$

Then $a = 7$, $b = -\frac{11}{3}$ and $c = -\frac{2}{3}$

$$\text{Sum of zeroes} = \frac{2}{3} + \frac{-1}{7} = \frac{14-3}{21} = \frac{11}{21} \dots\dots (i)$$

$$\text{Also, } \frac{-b}{a} = \frac{-\left(-\frac{11}{3}\right)}{7} = \frac{11}{21} \dots\dots (ii)$$

From (i) and (ii)

$$\text{Sum of zeroes} = \frac{-b}{a}$$

$$\text{Now, product of zeroes} = \frac{2}{3} \times \frac{-1}{7} = \frac{-2}{21} \dots\dots (iii)$$

$$\text{Also, } \frac{c}{a} = \frac{\frac{-2}{3}}{7} = \frac{-2}{21} \dots\dots (iv)$$

From (iii) and (iv)

$$\text{Product of zeroes} = \frac{c}{a}$$

31. In the given AP let the first term = a,

And common difference = d

Now, in general n^{th} term of an A.P is given by $T_n = a + (n-1)d$

$$T_{10} = a + 9d = 52 \dots\dots\dots (1) \text{ [given]}$$

$$a + 16d = 20 + a + 12d \text{ [given]}$$

$$4d = 20$$

$$d = 5$$

Substitute it in equation 1

$$a + 9(5) = 52$$

$$a = 7$$

Therefore, the required AP is

7, 12, 17, 22,

32. Given,

$$\tan \theta = \frac{1}{\sqrt{2}}$$

$$\therefore \cot \theta = \frac{1}{\tan \theta} = \sqrt{2} \Rightarrow \cot^2 \theta = 2$$

We know that, $\sec^2 \theta = 1 + \tan^2 \theta$

$$\therefore \sec^2 \theta = 1 + \left(\frac{1}{\sqrt{2}}\right)^2$$

$$\Rightarrow \sec^2 \theta = \frac{3}{2}$$

Also,

$$\operatorname{cosec}^2 \theta = 1 + \cot^2 \theta$$

$$\Rightarrow \operatorname{cosec}^2 \theta = 1 + 2$$

$$\Rightarrow \operatorname{cosec}^2 \theta = 3$$

Now,

$$\frac{\operatorname{cosec}^2 \theta - \sec^2 \theta}{\operatorname{cosec}^2 \theta + \cot^2 \theta}$$

$$= \frac{3 - \frac{3}{2}}{3 + 2}$$

$$= \frac{\frac{3}{2}}{5}$$

$$= \frac{3}{10}$$

$$\text{Hence, } \frac{\operatorname{cosec}^2 \theta - \sec^2 \theta}{\operatorname{cosec}^2 \theta + \cot^2 \theta} = \frac{3}{10}$$

OR

Given that,

$$\sin \theta + \cos \theta = m, \sec \theta + \operatorname{cosec} \theta = n.$$

Consider LHS

$$n(m^2 - 1) = (\sec \theta + \operatorname{cosec} \theta)[(\cos \theta + \sin \theta)^2 - 1]$$

$$= (\sec \theta + \operatorname{cosec} \theta)[\cos^2 \theta + \sin^2 \theta + 2\sin \theta \cos \theta - 1]$$

$$= (\sec \theta + \operatorname{cosec} \theta)[2\sin \theta \cos \theta] \quad \{\text{since } \cos^2 \theta + \sin^2 \theta = 1\}$$

$$= \sec \theta \cdot 2\sin \theta \cos \theta + \operatorname{cosec} \theta \cdot 2\sin \theta \cos \theta$$

$$= 2\sin \theta + 2\cos \theta$$

$$= 2[\sin \theta + \cos \theta]$$

$$= 2m$$

33.

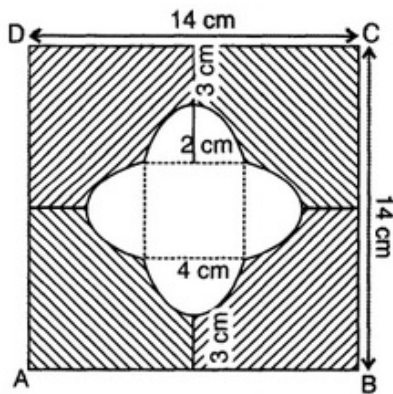

$$\text{Area of square ABCD} = \text{side} \times \text{side} = 14 \times 14 = 196 \text{ cm}^2$$

Radius of the semi-circle formed inside = 2 cm

$$\text{Area of 4 semi-circle} = 4 \times \frac{1}{2} \pi r^2$$

$$= 4 \times \frac{1}{2} \times (3.14) \times (2)^2$$

$$= 2 \times 3.14 \times 2 \times 2$$

$$= 25.12 \text{ cm}^2$$

Length of the side of square formed inside the semi-circles = 4 cm.

$$\text{Area of the square} = \text{side} \times \text{side} = 4 \times 4 = 16 \text{ cm}^2$$

Area of the shaded region = Area of square ABCD - (Area of 4 semi-circles + Area of square)

$$= 196 - (25.12 + 16)$$

$$= 196 - 41.12$$

$$= 154.88 \text{ cm}^2$$

So, area of shaded region is = 154.88 cm².

34. There are 100 cards in the box out of which one card can be drawn in 100 ways.

Total number of elementary events = 100

i. From numbers 2 to 101, there are 50 even numbers, namely, 2, 4, 6, 8, ..., 100.

Out of these 50 even numbered cards, one card can be chosen in 50 ways.

Favourable number of elementary events = 50

$$\text{Hence, } P(\text{Getting an even numbered card}) = \frac{50}{100} = \frac{1}{2}$$

ii. There are 12 cards bearing numbers less than 14 i.e. numbers 2, 3, 4, 5, 13

Favourable number of elementary events = 12

$$\text{Hence, required probability} = \frac{12}{100} = \frac{3}{25}$$

iii. Those numbers from 2 to 101 which are perfect squares are

4,9,16,25,36,49,64,81,100 i.e.

squares of 2,3,4,5,..., and 10 respectively.

Therefore, there are 9 cards marked with the numbers which are perfect squares.

Favourable number of elementary events = 9

Hence, $P(\text{Getting a card marked with a number which is a perfect square}) = \frac{9}{100}$

iv. Prime numbers less than 20 in the numbers from 2 to 101 are 2,3,5,7,11,13,17 and 19.

Thus, there are 8 cards marked with prime numbers less than 20.

Out of these 8 cards one card can be chose in 8 ways.

Favourable number of elementary events = 8

Hence, $P(\text{Getting a card marked with a prime number less than 20}) = \frac{8}{100} = \frac{2}{25}$

Section D

35. Required: To draw a pair of tangents to a circle of radius 5cm which are inclined to each other at a angle of 60° .

Steps of construction:

- i. Draw a circle of radius 5 cm with centre O.
- ii. Draw an angle AOB of 120° .
- iii. At A and B, draw 90° angles which meet at C.

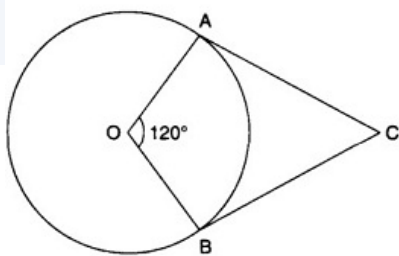

Then AC and BC are the required tangents which are inclined to each other at an angle of 60° .

Justification:

$\therefore \angle OAC = 90^\circ$ [By construction]

And OA is a radius

\therefore AC is a tangent to the circle.

$\therefore \angle OBC = 90^\circ$ [By construction]

and OB is a radius

\therefore BC is a tangent to the circle.

Now, in quadrilateral OACB

$$\angle AOB + \angle OAC + \angle OBC + \angle ACB = 360^\circ$$

[Angle sum property of a quadrilateral]

$$\Rightarrow 120^\circ + 90^\circ + 90^\circ + \angle ACB = 360^\circ$$

$$\Rightarrow 300^\circ + \angle ACB = 360^\circ$$

$$\Rightarrow \angle ACB = 360^\circ - 300^\circ = 60^\circ$$

OR

Steps of construction:-

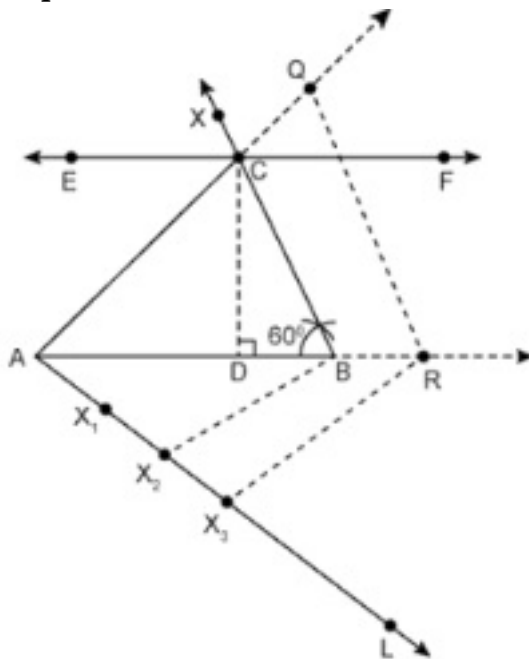

- i. Draw a line segment AB of length 5 cm.
- ii. Taking B as point construct an angle measure of 60° using a compass.
- iii. Name the angle as angle ABX.
- iv. Draw a line EF at a height of 3 cm such that it is parallel to the line segment AB. It must intersect ray BX at point C. Now join AC.
- v. Draw CD perpendicular to AB. CD is the altitude of $\triangle ABC$ having height 3 cm
- vi. $\triangle AQR$ is 1.5 times that of the corresponding sides of $\triangle ACB$, i.e $3/2$ times the corresponding sides of $\triangle ACB$.
- vii. Draw any ray AL making acute angle $\angle BAL$ with AB.
- viii. Mark three points X_1, X_2, X_3 on AL.

- ix. Join BX_2 , and draw line parallel to it passing from X_3 , intersecting AB extended at R .
- x. Draw line parallel to CB through R to intersect AC extended at Q .
- xi. $\triangle ARQ$ is the required triangle.

36. Since BD is a line and EC is a ray on it.

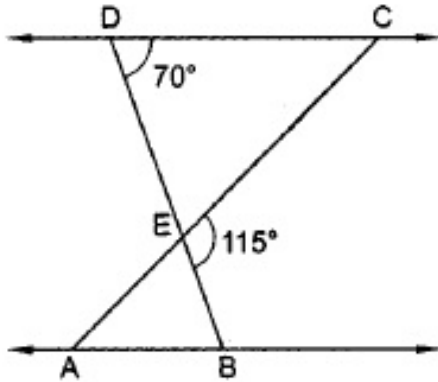

$$\therefore \angle DEC + \angle BEC = 180^\circ$$

$$\Rightarrow \angle DEC + 115^\circ = 180^\circ$$

$$\Rightarrow \angle DEC = 180^\circ - 115^\circ = 65^\circ$$

But, $\angle AEB = \angle DEC$ [Vertically opposite angles]

$$\therefore \angle AEB = 65^\circ$$

In $\triangle CDE$, we have

$$\angle CDE + \angle DEC + \angle DCE = 180^\circ$$

$$\Rightarrow 70^\circ + 65^\circ + \angle DCE = 180^\circ$$

$$\Rightarrow \angle DCE = 180^\circ - 135^\circ = 45^\circ$$

It is given that $\triangle EDC \sim \triangle EBA$

$$\therefore \angle EBA = \angle EDC, \angle EAB = \angle ECD$$

$$\Rightarrow \angle EBA = 70^\circ \text{ and } \angle EAB = 45^\circ [\because \angle ECD = \angle DCE = 45^\circ]$$

Hence, $\angle DEC = 65^\circ, \angle DCE = 45^\circ, \angle EAB = 45^\circ, \angle AEB = 65^\circ$ and $\angle EBA = 70^\circ$.

37. The given system of equations is $kx - y - 2 = 0, 6x - 2y - 3 = 0$.

This is of the form

$$a_1x + b_1y + c_1 = 0 \text{ and } a_2x + b_2y + c_2 = 0$$

$$a_1 = k, b_1 = -1, c_1 = -2$$

$$a_2 = 6, b_2 = -2, c_2 = -3$$

- i. For a unique solution, we must have $\frac{a_1}{a_2} \neq \frac{b_1}{b_2}$

$$\therefore \frac{k}{6} \neq \frac{-1}{-2} \Rightarrow \frac{k}{6} \neq \frac{1}{2} \Rightarrow k \neq 3$$

Hence, the given system of equations will have a unique solution when $k \neq 3$.

ii. For no solution, we must have $\frac{a_1}{a_2} = \frac{b_1}{b_2} \neq \frac{c_1}{c_2}$

$$\therefore \frac{k}{6} = \frac{-1}{-2} \neq \frac{-2}{-3}$$

$$\Rightarrow \frac{k}{6} = \frac{1}{2} \neq \frac{2}{3}$$

$$\Rightarrow \frac{k}{6} = \frac{1}{2} \text{ and } \frac{k}{6} \neq \frac{2}{3} \Rightarrow k = 3 \text{ and } k \neq 4$$

Clearly, $k = 3$ also satisfies the condition $k \neq 4$. Hence, the given system of equations will have no solution when $k = 3$.

iii. For infinitely many solutions, we must have

$$\frac{a_1}{a_2} = \frac{b_1}{b_2} = \frac{c_1}{c_2}$$

i.e., $\frac{k}{6} = \frac{1}{2} = \frac{1}{3}$, which is never possible, as $\frac{1}{2} \neq \frac{1}{3}$

Hence, there is no real value of k for which the given system of equations has infinitely many solutions.

OR

Given equations, $2x - 3y + 13 = 0$ and $3x - 2y + 12 = 0$.

Now, $2x - 3y + 13 = 0$

$$\Rightarrow y = \frac{13+2x}{3}$$

When $x=1$ then, $y=5$

When $x=4$ then, $y=7$

Thus, we have the following table giving points on the line $2x - 3y + 13 = 0$.

| | | |
|----------|---|---|
| x | 1 | 4 |
| y | 5 | 7 |

Now, $3x - 2y + 12 = 0$

$$\Rightarrow y = \frac{12+3x}{2}$$

When $x=0$ then, $y=6$

When $x=-2$ then, $y=3$

Thus, we have the following table giving points on the line $3x - 2y + 12 = 0$.

| | | |
|----------|---|----|
| x | 0 | -2 |
| y | 6 | 3 |

Graph:

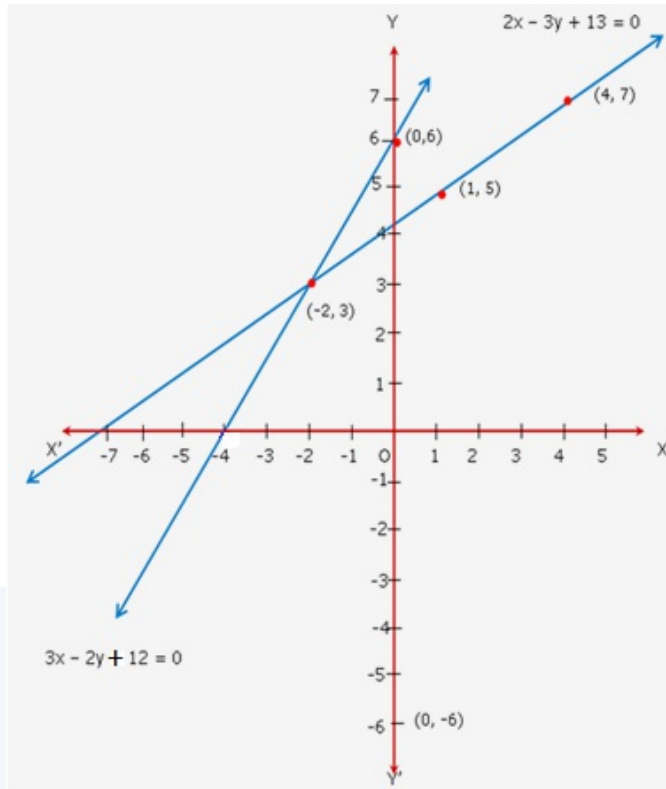

Since, the two graphs intersect at $(-2, 3)$.

Hence, $x = -2$ and $y = 3$.

38. Here VAB is the solid metallic cone. The height of this cone is 20 cm (given).
If this right circular cone is cut by a plane parallel to its base at a point O' such that $VO' = O'O$ i.e. O' is the midpoint of VO .

Now, r_1 and r_2 be the radii of circular ends of the frustum $ABB'A'$.

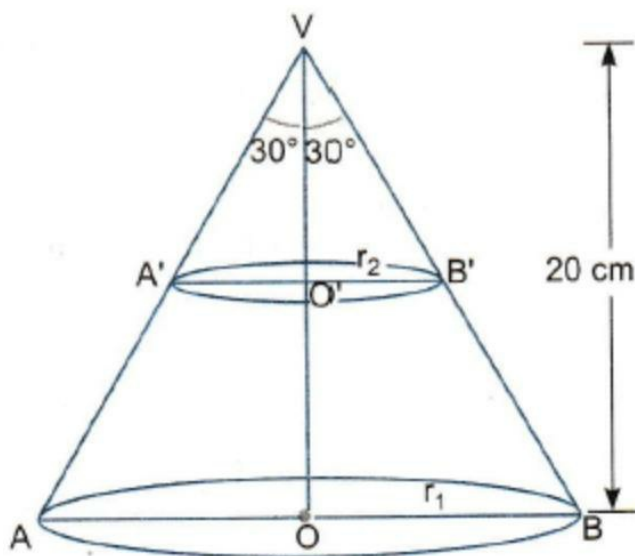

In triangles VOA and VO'A', we have
 $\tan 30^\circ = \frac{OA}{VO}$ and $\tan 30^\circ = \frac{O'A'}{VO'}$

$$\Rightarrow \frac{1}{\sqrt{3}} = \frac{r_1}{20} \text{ and } \frac{1}{\sqrt{3}} = \frac{r_2}{10}$$

$$\Rightarrow r_1 = \frac{20}{\sqrt{3}} \text{ cm and } r_2 = \frac{10}{\sqrt{3}} \text{ cm}$$

Let V be the volume of the frustum. Then,

$$V = \frac{1}{3}\pi (r_1^2 + r_2^2 + r_1r_2) h$$

$$\Rightarrow V = \frac{\pi}{3} \left(\frac{400}{3} + \frac{100}{3} + \frac{200}{3} \right) \times 10$$

$$= \frac{10\pi}{3} \left(\frac{400}{3} + \frac{100}{3} + \frac{200}{3} \right)$$

$$= \frac{10\pi}{3} \times \frac{700}{3}$$

$$= \frac{7000\pi}{9} \text{ cm}^3$$

Let the length of the wire of $\frac{1}{16}$ cm diameter be l cm and V_1 be the volume of the metal used in the wire.

$$V_1 = \pi \times \left(\frac{1}{32} \right)^2 \times l \left[\because \text{radius} = \frac{1}{32} \text{ cm} \right]$$

$$\Rightarrow V_1 = \frac{\pi l}{1024} \text{ cm}^3$$

The frustum is recast into a wire of length/cm and diameter $\frac{1}{16}$ cm.

\therefore The volume of the metal used in the wire = The volume of the frustum

$$\Rightarrow V_1 = V$$

$$\Rightarrow \frac{\pi l}{1024} = \frac{7000\pi}{9}$$

The length of the wire will be

$$\Rightarrow \text{length} = \frac{7000\pi}{9} \times \frac{1024}{\pi} \text{ cm} = \frac{7000}{9} \times 1024$$

$$= 7964.44 \text{ metre}$$

Hence, the length of the wire will be 7964.40 metre.

OR

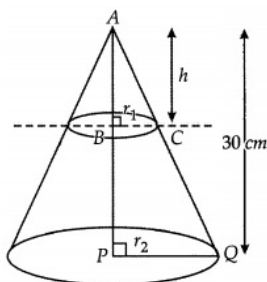

According to the question, The height of a cone is 30 cm. From its topside a small cone is cut by a plane parallel to its base.

Let the radii of smaller cone and original cone be r_1 and r_2 respectively and the height of smaller cone be h .

$$\triangle ABC \sim \triangle APQ$$

$$\Rightarrow \frac{h}{30} \sim \frac{r_1}{r_2} \dots(1)$$

Volume smaller cone = $\frac{1}{27} \times$ Volume of original cone

$$\Rightarrow \frac{1}{3} \pi r_1^2 \times h = \frac{1}{27} \times \frac{1}{3} \pi r_2^2 \times 30$$

$$\Rightarrow \left(\frac{r_1}{r_2}\right)^2 \times \frac{h}{30} = \frac{1}{27}$$

$$\Rightarrow \left(\frac{h}{30}\right)^2 \times \frac{h}{30} = \frac{1}{27}$$

(Using $\frac{h}{30} = \frac{r_1}{r_2}$ From (i))

$$\Rightarrow \left(\frac{h}{30}\right)^3 = \frac{1}{27}$$

$$\Rightarrow h^3 = \frac{30 \times 30 \times 30}{27}$$

$$h = 10 \text{ cm}$$

Hence, required height = $(30 - 10) = 20 \text{ cm}$

39. Let SP be the statue = 1.46 m(given)

Suppose PB be the pedestal = h metre

According to question angles of elevation of S and P are 60° and 45° respectively.

Further suppose $AB = x \text{ m}$,

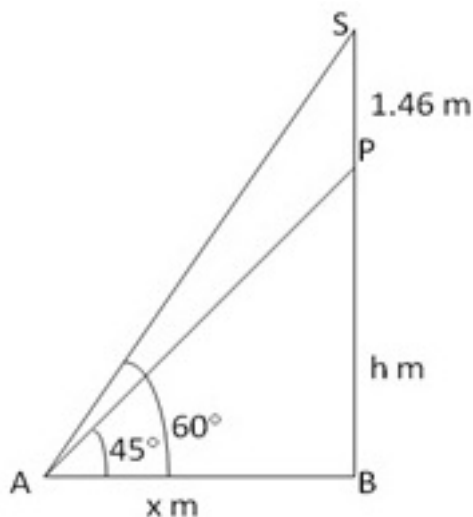

In right $\triangle ABS$,

$$\frac{SB}{AB} = \tan 60^\circ = \sqrt{3}$$

$$\Rightarrow \frac{h+1.46}{x} = \sqrt{3} \dots\dots\dots(i)$$

In right $\triangle PAB$,

$$\frac{PB}{AB} = \tan 45^\circ = 1$$

$$\therefore h = x \dots\dots\dots(ii)$$

Putting $x = h$ in (i), we get

$$\frac{h+1.46}{h} = \sqrt{3} \Rightarrow h + 1.46 = \sqrt{3}h$$

$$\text{or } h(\sqrt{3} - 1) = 1.46 \therefore h = \frac{1.46}{\sqrt{3}-1} \times \frac{\sqrt{3}+1}{\sqrt{3}+1}$$

$$\therefore h = \frac{1.46}{2} \times (\sqrt{3} + 1) = 0.73 \times 2.732$$

$$= 2\text{m (nearly)}$$

Thus, height of the pedestal = 2m

40. Table:

| Class Interval | Frequency f_i | Mid value x_i | $f_i x_i$ | Cumulative Frequency |
|----------------|-----------------|-----------------|-----------|-----------------------|
| 0 - 10 | 6 | 5 | 30 | 6 |
| 10 - 20 | 8 | 15 | 120 | 14 |
| 20 - 30 | 10 | 25 | 250 | 24 |
| 30 - 40 | 15 | 35 | 525 | 39 |
| 40 - 50 | 5 | 45 | 225 | 44 |
| 50 - 60 | 4 | 55 | 220 | 48 |
| 60 - 70 | 2 | 65 | 130 | 50 |
| | $\sum f_i = 50$ | | | $\sum f_i u_i = 1500$ |

i. Mean = $\frac{\sum f_i x_i}{\sum f_i} = \frac{1500}{50} = 30$

ii. Median

$$N = 50 \Rightarrow \frac{N}{2} = 25$$

median class is 30 - 40.

$$\therefore l = 30, h = 10, f = 15, \text{c.f.} = 24$$

$$\begin{aligned}\text{Median} &= l + \left\{ h \times \frac{\left(\frac{N}{2} - cf\right)}{f} \right\} \\ &= 30 + \left\{ 10 \times \frac{25-24}{15} \right\} \\ &= 30 + 0.67 = 30.67\end{aligned}$$

iii. Mode

Maximum frequency = 15

Hence, modal class is 30 - 40.

$$\begin{aligned}\text{Now, Mode} &= x_k + h \left\{ \frac{(f_k - f_{k-1})}{(2f_k - f_{k-1} - f_{k+1})} \right\} \\ &= 30 + 10 \left\{ \frac{15-10}{2(15)-10-5} \right\} \\ &= 30 + 3.33 = 33.33\end{aligned}$$



Vidya Champ