

रोल नं.

--	--	--	--	--	--	--

Roll No.

परीक्षार्थी कोड को उत्तर-पुस्तिका के मुख-पृष्ठ पर अवश्य लिखें ।

Candidates must write the Code on the title page of the answer-book.

- कृपया जाँच कर लें कि इस प्रश्न-पत्र में मुद्रित पृष्ठ 15 हैं ।
- प्रश्न-पत्र में दाहिने हाथ की ओर दिए गए कोड नम्बर को छात्र उत्तर-पुस्तिका के मुख-पृष्ठ पर लिखें ।
- कृपया जाँच कर लें कि इस प्रश्न-पत्र में 26 प्रश्न हैं ।
- कृपया प्रश्न का उत्तर लिखना शुरू करने से पहले, प्रश्न का क्रमांक अवश्य लिखें ।
- इस प्रश्न-पत्र को पढ़ने के लिए 15 मिनट का समय दिया गया है । प्रश्न-पत्र का वितरण पूर्वाह्न में 10.15 बजे किया जायेगा । 10.15 बजे से 10.30 बजे तक छात्र केवल प्रश्न-पत्र को पढ़ेंगे और इस अवधि के दौरान वे उत्तर-पुस्तिका पर कोई उत्तर नहीं लिखेंगे ।
- Please check that this question paper contains 15 printed pages.
- Code number given on the right hand side of the question paper should be written on the title page of the answer-book by the candidate.
- Please check that this question paper contains 26 questions.
- **Please write down the Serial Number of the question before attempting it.**
- 15 minute time has been allotted to read this question paper. The question paper will be distributed at 10.15 a.m. From 10.15 a.m. to 10.30 a.m., the students will read the question paper only and will not write any answer on the answer-book during this period.

भौतिक विज्ञान (सैद्धांतिक)

PHYSICS (Theory)

निर्धारित समय : 3 घंटे

अधिकतम अंक : 70

Time allowed : 3 hours

Maximum Marks : 70

सामान्य निर्देश :

- इस प्रश्न-पत्र में कुल 26 प्रश्न हैं । सभी प्रश्न अनिवार्य हैं ।
- इस प्रश्न-पत्र के 5 भाग हैं : खण्ड-क, खण्ड-ख, खण्ड-ग, खण्ड-घ और खण्ड-ङ ।
- खण्ड-क में 5 प्रश्न प्रत्येक 1 अंक का, खण्ड-ख में 5 प्रश्न प्रत्येक 2 अंक के, खण्ड-ग में 12 प्रश्न प्रत्येक 3 अंक के, खण्ड-घ में 4 अंक का एक मूल्याधारित प्रश्न और खण्ड-ङ में 3 प्रश्न प्रत्येक 5 अंक के दिए गए हैं ।
- समग्र पर कोई विकल्प नहीं है । फिर भी 2 अंक के 1 प्रश्न, 3 अंक के 1 प्रश्न और 5 अंकों के 3 प्रश्नों में भीतरी विकल्प दिए गए हैं । ऐसे प्रश्नों में आपको विकल्पों में से एक को हल करना है ।

(v) वहाँ आवश्यक हो, वहाँ आप भौतिक अचरों के निम्नलिखित मूल्यों का उपयोग कर सकते हैं :

$$c = 3 \times 10^8 \text{ m/s}$$

$$h = 6.63 \times 10^{-34} \text{ Js}$$

$$e = 1.6 \times 10^{-19} \text{ C}$$

$$\mu_0 = 4\pi \times 10^{-7} \text{ T m A}^{-1}$$

$$\epsilon_0 = 8.854 \times 10^{-12} \text{ C}^2 \text{ N}^{-1} \text{ m}^{-2}$$

$$\frac{1}{4\pi\epsilon_0} = 9 \times 10^9 \text{ N m}^2 \text{ C}^{-2}$$

$$\text{इलेक्ट्रॉन का द्रव्यमान} = 9.1 \times 10^{-31} \text{ kg}$$

$$\text{न्यूट्रॉन का द्रव्यमान} = 1.675 \times 10^{-27} \text{ kg}$$

$$\text{प्रोटॉन का द्रव्यमान} = 1.673 \times 10^{-27} \text{ kg}$$

$$\text{ऐवोगेड्रो संख्या} = 6.023 \times 10^{23} \text{ प्रति ग्राम मोल}$$

$$\text{बॉल्ट्ज़मान नियतांक} = 1.38 \times 10^{-23} \text{ JK}^{-1}$$

General Instructions :

(i) All questions are compulsory. There are 26 questions in all.

(ii) This question paper has **five** sections : Section A, Section B, Section C, Section D and Section E.

(iii) Section A contains **five** questions of **one** mark each, Section B contains **five** questions of **two** marks each, Section C contains **twelve** questions of **three** marks each, Section D contains **one** value based question of **four** marks and Section E contains **three** questions of **five** marks each.

(iv) There is no overall choice. However, an internal choice has been provided in **one** question of **two** marks, **one** question of **three** marks and all the **three** questions of **five** marks weightage. You have to attempt only **one** of the choices in such questions.

(v) You may use the following values of physical constants wherever necessary :

$$c = 3 \times 10^8 \text{ m/s}$$

$$h = 6.63 \times 10^{-34} \text{ Js}$$

$$e = 1.6 \times 10^{-19} \text{ C}$$

$$\mu_0 = 4\pi \times 10^{-7} \text{ T m A}^{-1}$$

$$\epsilon_0 = 8.854 \times 10^{-12} \text{ C}^2 \text{ N}^{-1} \text{ m}^{-2}$$

$$\frac{1}{4\pi\epsilon_0} = 9 \times 10^9 \text{ N m}^2 \text{ C}^{-2}$$

$$\text{Mass of electron} = 9.1 \times 10^{-31} \text{ kg}$$

$$\text{Mass of neutron} = 1.675 \times 10^{-27} \text{ kg}$$

$$\text{Mass of proton} = 1.673 \times 10^{-27} \text{ kg}$$

$$\text{Avogadro's number} = 6.023 \times 10^{23} \text{ per gram mole}$$

$$\text{Boltzmann constant} = 1.38 \times 10^{-23} \text{ JK}^{-1}$$

खण्ड – क
SECTION – A

1. श्रेणी LCR परिपथ में अनुनाद के 'गुणता कारक' की परिभाषा लिखिए । इसका SI मात्रक क्या है ? 1

Define 'quality factor' of resonance in series LCR circuit. What is its SI unit ?

2. चित्र में दर्शाए अनुसार कोई बिन्दुकित आवेश +Q किसी बिन्दु O पर स्थित है । उल्लेख कीजिए कि क्या विभवान्तर $V_A - V_B$ धनात्मक, ऋणात्मक अथवा शून्य है । 1

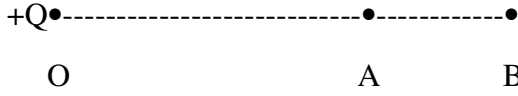

A point charge +Q is placed at point O as shown in the figure. Is the potential difference $V_A - V_B$ positive, negative or zero ?

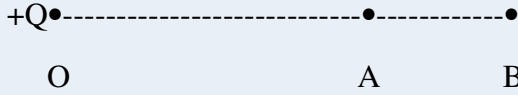

3. यदि किसी गोलीय गौसीय पृष्ठ की त्रिज्या में वृद्धि कर दी जाए, तो उसमें परिवर्द्ध किसी बिन्दुकित आवेश के कारण विद्युत क्षेत्र में क्या परिवर्तन होगा ? 1

How does the electric flux due to a point charge enclosed by a spherical Gaussian surface get affected when its radius is increased ?

4. विमान संचालन की रडार प्रणाली के लिए सूक्ष्म तरंगों को उपयुक्त क्यों माना जाता है ? 1

Why are micro waves considered suitable for radar systems used in aircraft navigation ?

5. चल कुण्डली गैल्वेनोमीटर का आधारित सिद्धान्त लिखिए । 1

Write the underlying principle of a moving coil galvanometer.

खण्ड – ख

SECTION – B

6. ब्रूस्टर नियम लिखिए ।

विभिन्न वर्णों के प्रकाश के लिए पारदर्शी माध्यम के ब्रूस्टर कोण का मान भिन्न-भिन्न होता है । कारण दीजिए । 2

State Brewster's law.

The value of Brewster angle for a transparent medium is different for light of different colours. Give reason.

7. संचार प्रणाली में उपयोग होने वाले पदों (i) संकीर्णन (क्षीणता) (ii) विमॉडुलन की व्याख्या कीजिए । 2

Explain the terms (i) Attenuation and (ii) Demodulation used in Communication System.

8. समान आवेश परन्तु विभिन्न द्रव्यमानों m_1 , m_2 ($m_1 > m_2$) के दो कणों A और B के $\frac{1}{\sqrt{V}}$ और दे-ब्रॉग्ली तरंगदैर्घ्य λ के बीच विचरण को दर्शाने के लिए ग्राफ खींचिए । यदि V त्वरक विभव को निरूपित करता है, तो इन दोनों में से कौन छोटे द्रव्यमान को प्रदर्शित करता है ? कारण दीजिए । 2

Plot a graph showing variation of de-Broglie wavelength λ versus $\frac{1}{\sqrt{V}}$, where V is accelerating potential for two particles A and B carrying same charge but of masses m_1 , m_2 ($m_1 > m_2$). Which one of the two represents a particle of smaller mass and why ?

9. दो सेल, जिनकी emf 1.5 V और 2.0 V तथा आन्तरिक प्रतिरोध क्रमशः 0.2 Ω तथा 0.3 Ω हैं, पार्श्व में संयोजित हैं । इनके तुल्य सेल की emf और आन्तरिक प्रतिरोध परिकलित कीजिए । 2

Two cells of emfs 1.5 V and 2.0 V having internal resistances 0.2 Ω and 0.3 Ω respectively are connected in parallel. Calculate the emf and internal resistance of the equivalent cell.

10. द्रव्यमान संख्या $A = 240$ तथा बन्धन ऊर्जा प्रति न्युक्लियॉन $BE/A = 7.6 \text{ MeV}$ का कोई नाभिक दो टुकड़ों में विखण्डित होता है जिनमें प्रत्येक के लिए $A = 120$ और $BE/A = 8.5 \text{ MeV}$ है। मुक्त-ऊर्जा परिकलित कीजिए।

2

अथवा

संलयन अभिक्रिया ${}^2_1\text{H} + {}^2_1\text{H} \longrightarrow {}^3_2\text{He} + \text{n}$, जबकि, बंधन ऊर्जा (BE) ${}^2_1\text{H}$ की 2.23 MeV तथा ${}^3_2\text{He}$ की 7.73 MeV है, में ऊर्जा परिकलित कीजिए।

A nucleus with mass number $A = 240$ and $BE/A = 7.6 \text{ MeV}$ breaks into two fragments each of $A = 120$ with $BE/A = 8.5 \text{ MeV}$. Calculate the released energy.

OR

Calculate the energy in fusion reaction :

${}^2_1\text{H} + {}^2_1\text{H} \longrightarrow {}^3_2\text{He} + \text{n}$, where BE of ${}^2_1\text{H} = 2.23 \text{ MeV}$ and of ${}^3_2\text{He} = 7.73 \text{ MeV}$.

खण्ड-ग

SECTION – C

11. (a) चुम्बकीय क्षेत्र B में वेग v से गतिमान किसी आवेशित कण पर लगने वाले चुम्बकीय बल के लिए व्यंजक लिखिए।
- (b) समान वेग से गतिमान कोई न्यूट्रॉन, इलेक्ट्रॉन और ऐल्फा कण चित्र में दर्शाए अनुसार पेपर के तल के भीतर जाते किसी एकसमान चुम्बकीय क्षेत्र में प्रवेश करते हैं। क्षेत्र में इनके पथ आरेखित कीजिए और अपने उत्तर की पुष्टि कीजिए।

3

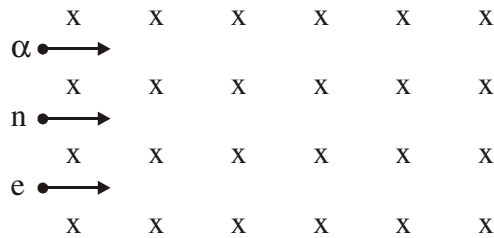

- (a) Write the expression for the magnetic force acting on a charged particle moving with velocity v in the presence of magnetic field B .

- (b) A neutron, an electron and an alpha particle moving with equal velocities, enter a uniform magnetic field going into the plane of the paper as shown. Trace their paths in the field and justify your answer.

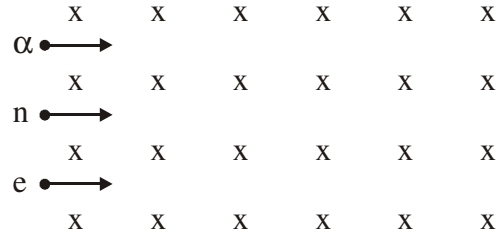

12. त्रिज्या 'a' के किसी वलय पर आवेश एकसमान रूप से वितरित है। इस वलय के अक्ष के किसी बिन्दु पर विद्युत तीव्रता E के लिए व्यंजक प्राप्त कीजिए। इस प्रकार यह दर्शाएँ कि इस वलय से लम्बी दूरी के बिन्दुओं के लिए यह बिन्दुविकृत आवेश की भाँति व्यवहार करता है। 3

A charge is distributed uniformly over a ring of radius 'a'. Obtain an expression for the electric intensity E at a point on the axis of the ring. Hence show that for points at large distances from the ring, it behaves like a point charge.

13. प्रकाश-विद्युत प्रभाव के उन तीन विशिष्ट लक्षणों का उल्लेख कीजिए जिनकी व्याख्या प्रकाश के तरंग सिद्धान्त के द्वारा नहीं की जा सकती, परन्तु केवल आइंस्टीन-समीकरण के उपयोग द्वारा ही की जा सकती है। 3

Write three characteristic features in photoelectric effect which cannot be explained on the basis of wave theory of light but can be explained only using Einstein's equation.

14. दो समान्तर पट्टिका संधारित्रों X तथा Y की पट्टिकाओं के क्षेत्र समान हैं और उनके बीच पृथक् भी समान हैं। X की पट्टिकाओं के बीच वायु है, जबकि Y में $\epsilon_r = 4$ का परावैद्युत माध्यम है।

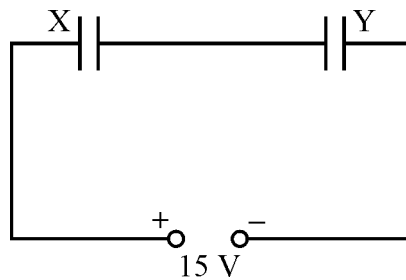

- (i) यदि संयोजन की तुल्य धारिता $4 \mu\text{F}$ है, तो प्रत्येक संधारित्र की धारिता परिकलित कीजिए।
(ii) X तथा Y की पट्टिकाओं के बीच विभवान्तर परिकलित कीजिए।
(iii) X तथा Y में संचित स्थिर विद्युत ऊर्जा के अनुपात का अनुमान लगाइए। 3

Two parallel plate capacitors X and Y have the same area of plates and same separation between them. X has air between the plates while Y contains a dielectric medium of $\epsilon_r = 4$.

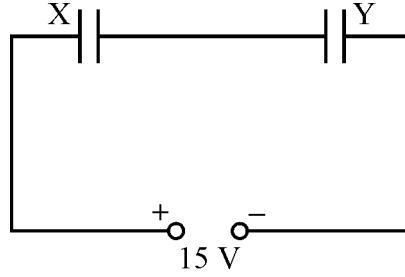

- (i) Calculate capacitance of each capacitor if equivalent capacitance of the combination is $4 \mu\text{F}$.
- (ii) Calculate the potential difference between the plates of X and Y.
- (iii) Estimate the ratio of electrostatic energy stored in X and Y.

15. (i) अन्योन्य प्रेरण की परिभाषा लिखिए ।

(ii) संलग्न कुण्डलियों के किसी युगल का अन्योन्य प्रेरण 1.5 H है । यदि एक कुण्डली में 0.5 s में धारा 0 से 20 A हो जाती है, तो अन्य कुण्डली में फ्लक्स-ग्रंथिका का परिवर्तन कितना होगा ? 3

(i) Define mutual inductance.

(ii) A pair of adjacent coils has a mutual inductance of 1.5 H . If the current in one coil changes from 0 to 20 A in 0.5 s , what is the change of flux linkage with the other coil ?

16. (a) निम्न आवृत्ति के सिग्नल के मॉड्युलन की आवश्यकता की न्यायसंगतता बताने वाले किन्हीं दो कारकों की व्याख्या कीजिए । 3

(b) आयाम मॉड्युलन की तुलना में आवृत्ति मॉड्युलन के दो लाभ लिखिए ।

(a) Explain any two factors which justify the need of modulating a low frequency signal.

(b) Write two advantages of frequency modulation over amplitude modulation.

17. दो लम्बे सीधे समान्तर चालकों से स्थायी धाराएँ I_1 और I_2 प्रवाहित हो रही हैं और इनके बीच पृथकन d है । यदि इन चालकों से प्रवाहित धाराओं की दिशा समान हैं, तो यह दर्शाइए कि किस प्रकार एक में उत्पन्न चुम्बकीय क्षेत्र दूसरे में आकर्षण बल उत्पन्न करता है । इस प्रकार इस बल के लिए व्यंजक प्राप्त कीजिए ।

एक ऐम्पियर की परिभाषा लिखिए ।

3

Two long straight parallel conductors carry steady current I_1 and I_2 separated by a distance d . If the currents are flowing in the same direction, show how the magnetic field set up in one produces an attractive force on the other. Obtain the expression for this force. Hence define one ampere.

18. दोलायमान आवेशों द्वारा किस प्रकार वैद्युत-चुम्बकीय तरंगें उत्पन्न होती हैं ?

Z-दिशा में संचरित होने वाली रेखिकतः ध्रुवित वैद्युत-चुम्बकीय तरंगों का आरेख खींचिए । दोलायमान विद्युत एवं चुम्बकीय क्षेत्रों की दिशाएँ भी इंगित कीजिए ।

3

अथवा

ऐम्पियर के परिपथीय नियम का मैक्सवेल का व्यापकीकरण लिखिए । यह दर्शाइए कि किसी संधारित्र के आवेशन की प्रक्रिया में, संधारित्र की पट्टिकाओं में उत्पन्न धारा

$$i = \epsilon_0 \frac{d\Phi_E}{dt} \text{ होती है ।}$$

यहाँ Φ_E संधारित्र की पट्टिकाओं को आवेशित करते समय उत्पन्न विद्युत फ्लक्स है ।

How are em waves produced by oscillating charges ?

Draw a sketch of linearly polarized em waves propagating in the Z-direction. Indicate the directions of the oscillating electric and magnetic fields.

OR

Write Maxwell's generalization of Ampere's Circuital Law. Show that in the process of charging a capacitor, the current produced within the plates of the capacitor is

$$i = \epsilon_0 \frac{d\Phi_E}{dt}$$

where Φ_E is the electric flux produced during charging of the capacitor plates.

19. (a) 20 cm वक्रता त्रिज्या के किसी अवतल दर्पण के सामने h ऊँचाई के किसी बिम्ब की दर्पण से वह दूरी परिकल्पित कीजिए जिस पर बिम्ब को रखने पर आवर्धन 2 का वास्तविक प्रतिबिम्ब प्राप्त हो। प्रतिबिम्ब की स्थिति भी ज्ञात कीजिए। 3

- (b) दर्पण सूत्र का प्रयोग करते हुए व्याख्या कीजिए, उत्तल दर्पण सदैव ही बिम्ब का आभासी प्रतिबिम्ब क्यों बनाते हैं।

- (a) Calculate the distance of an object of height h from a concave mirror of radius of curvature 20 cm, so as to obtain a real image of magnification 2. Find the location of image also.

- (b) Using mirror formula, explain why does a convex mirror always produce a virtual image.

20. (i) ट्रांजिस्टर के तीन खण्डों का संक्षेप में वर्णन कीजिए।

- (ii) उभयनिष्ठ उत्सर्जक विन्यास में n-p-n ट्रांजिस्टर के निर्गत और निवेश अभिलाक्षणिकों के अध्ययन के लिए परिपथ आरेख खींचिए। इस परिपथ के उपयोग द्वारा व्याख्या कीजिए कि निवेश, निर्गत अभिलाक्षणिक किस प्रकार प्राप्त किए जाते हैं। 3

- (i) Write the functions of three segments of a transistor.

- (ii) Draw the circuit diagram for studying the input and output characteristics of n-p-n transistor in common emitter configuration. Using the circuit, explain how input, output characteristics are obtained.

21. यह दर्शाते हुए, कि किसी दूरस्थ बिम्ब से आने वाली प्रकाश किरणें किस प्रकार नेत्रिका द्वारा ग्रहण की जाती हैं, परावर्ती दूरदर्शक का व्यवस्था किरण आरेख खींचिए । अपवर्ती दूरदर्शकों की तुलना में इसके दो महत्वपूर्ण लाभ लिखिए ।

3

Draw a schematic ray diagram of reflecting telescope showing how rays coming from a distant object are received at the eye-piece. Write its two important advantages over a refracting telescope.

22. (i) स्थायी कक्षाओं को परिभाषित करने वाली बोर की क्वांटमीकरण की शर्त का उल्लेख कीजिए । दे-ब्रॉग्ली अभिगृहीत स्थायी कक्षाओं की व्याख्या किस प्रकार करता है ?

3

- (ii) नीचे दर्शाए गए ऊर्जा-स्तर आरेख से तीन तरंगदैर्घ्यों λ_1 , λ_2 और λ_3 में संबंध ज्ञात कीजिए ।

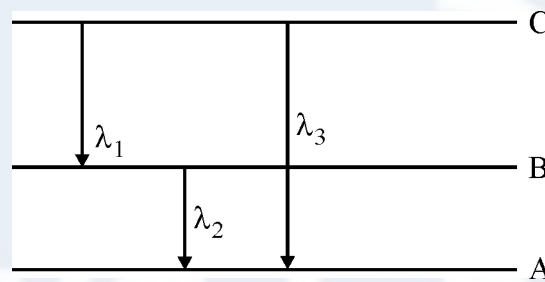

- (i) State Bohr's quantization condition for defining stationary orbits. How does de Broglie hypothesis explain the stationary orbits ?
- (ii) Find the relation between the three wavelengths λ_1 , λ_2 and λ_3 from the energy level diagram shown below.

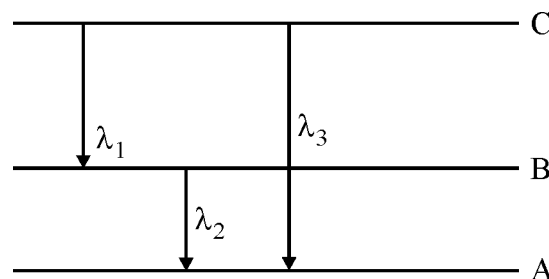

खण्ड – घ

SECTION – D

23. मीता के पिताजी उसे उसके स्कूल ले जा रहे थे । ट्रैफिक सिग्नल पर मीता ने यह देखा कि ट्रैफिक लाइट में केवल एक ही बल्ब नहीं हैं, वरन् उसमें छोटी-छोटी बहुत सी लाइट लगी हैं । जब मीता ने अपने पिताजी से इसके बारे में प्रश्न पूछा, तो उन्होंने इसका कारण स्पष्ट किया ।

उपरोक्त जानकारी के आधार पर निम्नलिखित प्रश्नों के उत्तर दीजिए :

- (i) मीता और उसके पिताजी ने किन मूल्यों का प्रदर्शन किया ?
- (ii) मीता के पिताजी ने क्या उत्तर दिया ?
- (iii) ट्रैफिक सिग्नलों में लगी इन छोटी लाइटों को क्या कहते हैं ? इनका प्रचालन किस प्रकार होता है ? 4

Meeta's father was driving her to the school. At the traffic signal she noticed that each traffic light was made of many tiny lights instead of a single bulb. When Meeta asked this question to her father, he explained the reason for this.

Answer the following questions based on above information :

- (i) What were the values displayed by Meeta and her father ?
- (ii) What answer did Meeta's father give ?
- (iii) What are the tiny lights in traffic signals called and how do these operate ?

खण्ड – ङ

SECTION – E

24. (i) अपवाह वेग की परिभाषा लिखिए ।
- (ii) इलेक्ट्रॉन-अपवाह के आधार पर मुक्त इलेक्ट्रॉनों की घनत्व संख्या और विश्रान्ति-काल के पदों में किसी चालक की प्रतिरोधकता के लिए व्यंजक व्युत्पन्न कीजिए । किसी चालक की प्रतिरोधकता किन कारकों पर निर्भर करती है ?
- (iii) मानक प्रतिरोधकों के निर्माण में कांस्टेन्टन और मैंगनिन जैसे मिश्रातुओं का उपयोग क्यों किया जाता है ? 5

अथवा

- (i) पोटेंशियोमीटर का कार्यकारी सिद्धान्त लिखिए ।
- (ii) नीचे दिए गए पोटेंशियोमीटर परिपथ में AB कोई एकसमान तार है, जिसकी लम्बाई 1 m तथा प्रतिरोध 10Ω है । तार के अनुदिश विभव प्रवणता तथा संतुलन-लम्बाई AO ($= l$) परिकलित कीजिए ।

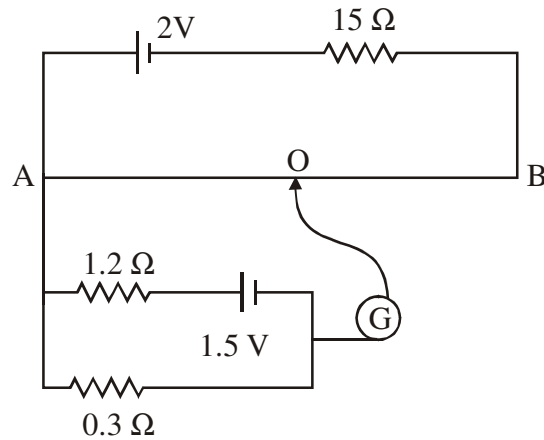

- (i) Define the term drift velocity.
- (ii) On the basis of electron drift, derive an expression for resistivity of a conductor in terms of number density of free electrons and relaxation time. On what factors does resistivity of a conductor depend ?
- (iii) Why alloys like constantan and manganin are used for making standard resistors ?

OR

- (i) State the principle of working of a potentiometer.
- (ii) In the following potentiometer circuit AB is a uniform wire of length 1 m and resistance 10Ω . Calculate the potential gradient along the wire and balance length AO ($= l$).

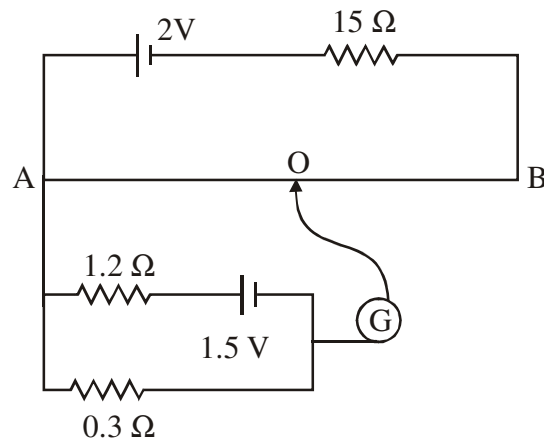

25. (i) यंग के द्विझिरी प्रयोग में पर्दे के किसी बिंदु पर (a) संपोषी, (b) विनाशी व्यतिकरण के लिए शर्त व्युत्पन्न कीजिए । पर्दे पर स्थिति 'x' और व्यतिकरण पैटर्न में तीव्रता में विचरण को दर्शाने के लिए ग्राफ खींचिए ।
- (ii) तीन विभेदनकारी लक्षणों की ओर संकेत करते हुए यंग के द्विझिरी प्रयोग के व्यतिकरण पैटर्न की एकल झिरी के विवर्तन पैटर्न से तुलना कीजिए ।

अथवा

- (i) प्रिज्म से गुजरने वाले प्रकाश के लिए आपतन कोण के फलन के रूप में विचलन कोण में विचरण को दर्शाने के लिए ग्राफ खींचिए । प्रिज्म कोण और न्यूनतम विचलन कोण के पदों में प्रिज्म के अपवर्तनांक के लिए व्यंजक व्युत्पन्न कीजिए ।
- (ii) वर्ण विक्षेपण क्या है ? विक्षेपण का कारण क्या है ?
- (iii) किसी समद्विबाहु समकोण प्रिज्म के एक फलक पर प्रकाश की कोई किरण अभिलम्बवत् आपतन करके चित्र में दर्शाए अनुसार पूर्ण परावर्तित होती है । काँच के अपवर्तनांक का न्यूनतम मान कितना होना चाहिए ? प्रासंगिक परिकलन भी कीजिए ।

5

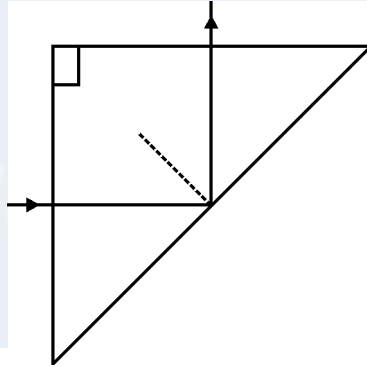

- (i) In Young's double slit experiment, deduce the condition for (a) constructive, and (b) destructive interference at a point on the screen. Draw a graph showing variation of intensity in the interference pattern against position 'x' on the screen.
- (ii) Compare the interference pattern observed in Young's double slit experiment with single slit diffraction pattern, pointing out three distinguishing features.

OR

- (i) Plot a graph to show variation of the angle of deviation as a function of angle of incidence for light passing through a prism. Derive an expression for refractive index of the prism in terms of angle of minimum deviation and angle of prism.
- (ii) What is dispersion of light ? What is its cause ?
- (iii) A ray of light incident normally on one face of a right isosceles prism is totally reflected as shown in fig. What must be the minimum value of refractive index of glass ? Give relevant calculations.

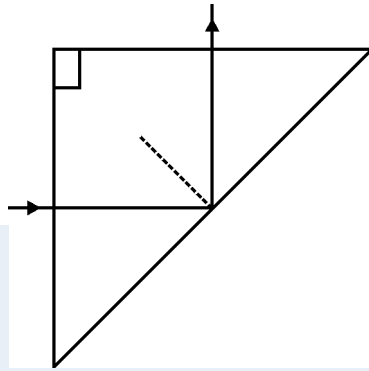

26. (i) वोल्टता $V = V_0 \sin \omega t$ का कोई ac स्रोत, L, C और R के किसी श्रेणी संयोजन से संयोजित है । फेज़र आरेख का उपयोग करके परिपथ की प्रतिबाधा तथा वोल्टता व धारा के बीच कला कोण के लिए व्यंजक प्राप्त कीजिए । वह स्थिति ज्ञात कीजिए जिसमें धारा और वोल्टता एक ही कला में होते हैं । इस स्थिति में परिपथ को क्या कहा जाता है ?

(ii) किसी LR श्रेणी परिपथ में, $X_L = R$ तथा परिपथ का शक्ति गुणांक P_1 है । जब इस परिपथ में C धारिता का संधारित्र श्रेणी क्रम में इस प्रकार लगाया जाता है, कि $X_L = X_C$ हो, तो शक्ति गुणांक P_2 हो जाता है । P_1/P_2 ज्ञात कीजिए ।

अथवा

(i) ट्रान्सफॉर्मर का कार्य लिखिए । इसका कार्यकारी सिद्धान्त उपयुक्त आरेख द्वारा समझाइए । इस युक्ति में होने वाले विभिन्न ऊर्जा-क्षयों का उल्लेख कीजिए ।

(ii) किसी आदर्श उच्चायी ट्रांसफार्मर की प्राथमिक कुण्डली में 100 फेरे हैं तथा इसका परिणमन अनुपात भी 100 है। निवेश वोल्टता और शक्ति क्रमशः 220 V और 1100 W हैं। परिकल्पित कीजिए :

- (a) द्वितीयक कुण्डली में फेरों की संख्या
- (b) प्राथमिक कुण्डली में धारा
- (c) द्वितीयक कुण्डली के सिरों पर वोल्टता
- (d) द्वितीयक कुण्डली में धारा
- (e) द्वितीयक कुण्डली में शक्ति

5

(i) An a.c. source of voltage $V = V_0 \sin \omega t$ is connected to a series combination of L, C and R. Use the phasor diagram to obtain expressions for impedance of the circuit and phase angle between voltage and current. Find the condition when current will be in phase with the voltage. What is the circuit in this condition called ?

(ii) In a series LR circuit $X_L = R$ and power factor of the circuit is P_1 . When capacitor with capacitance C such that $X_L = X_C$ is put in series, the power factor becomes P_2 . Calculate P_1/P_2 .

OR

(i) Write the function of a transformer. State its principle of working with the help of a diagram. Mention various energy losses in this device.

(ii) The primary coil of an ideal step up transformer has 100 turns and transformation ratio is also 100. The input voltage and power are respectively 220 V and 1100 W. Calculate

- (a) number of turns in secondary
- (b) current in primary
- (c) voltage across secondary
- (d) current in secondary
- (e) power in secondary



MARKING SCHEME

Q. No.	Expected Answer / Value Points	Marks	Total Marks						
	<u>SECTION (A)</u>								
Set1,Q1 Set2,Q4 Set3,Q2	Positive	1	1						
Set1,Q2 Set2,Q5 Set3,Q3	Electric flux remains unaffected. [NOTE: (As per the Hindi translation), change in Electric field is being asked, hence give credit if student writes answer as decreases]	1	1						
Set1,Q3 Set2,Q1 Set3,Q5	A current carrying coil, in the presence of magnetic field, experiences a torque, which produces proportionate deflection. [Alternatively (deflection) $\theta \propto \tau$ (Torque)]	1	1						
Set1,Q4 Set2,Q2 Set3,Q4	Due to their short wavelengths, (they are suitable for radar system used in aircraft navigation).	1	1						
Set1,Q5 Set2,Q3 Set3,Q1	Quality factor $Q = \frac{\omega_0}{2\Delta\omega}$, [Alternatively Quality factor $Q = \frac{\omega_0 L}{R}$, Alternatively, It gives the sharpness of the resonance circuit.] It has no unit.	$\frac{1}{2}$ $\frac{1}{2}$	 1						
Set1,Q6 Set2,Q9 Set3,Q7	<u>SECTION (B)</u>								
	<table border="1" style="width: 100%;"> <tr> <td colspan="2">Explanation of the terms</td> </tr> <tr> <td>(i) Attenuation</td> <td style="text-align: right;">1</td> </tr> <tr> <td>(ii) Demodulation</td> <td style="text-align: right;">1</td> </tr> </table> <p>(i) The loss of strength of a signal while propagating through a medium. (ii) The process of retrieval of information, from the carrier wave, at the receiver.</p>	Explanation of the terms		(i) Attenuation	1	(ii) Demodulation	1	1 1	2
Explanation of the terms									
(i) Attenuation	1								
(ii) Demodulation	1								
Set1,Q7 Set2,Q10 Set3,Q8	<table border="1" style="width: 100%;"> <tr> <td>Plotting of graph</td> <td style="text-align: right;">$\frac{1}{2} + \frac{1}{2}$</td> </tr> <tr> <td>Identification of line representing lower mass</td> <td style="text-align: right;">$\frac{1}{2}$</td> </tr> <tr> <td>Reason</td> <td style="text-align: right;">$\frac{1}{2}$</td> </tr> </table>	Plotting of graph	$\frac{1}{2} + \frac{1}{2}$	Identification of line representing lower mass	$\frac{1}{2}$	Reason	$\frac{1}{2}$		
Plotting of graph	$\frac{1}{2} + \frac{1}{2}$								
Identification of line representing lower mass	$\frac{1}{2}$								
Reason	$\frac{1}{2}$								

SECTION (C)

Set1,Q11
Set2,Q14
Set3,Q12

Obtaining an expression for Electric field intensity	2
Showing behavior at large distance	1

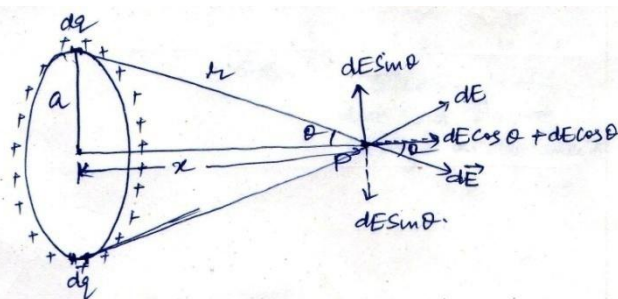

Net Electric Field at point P = $\int_0^{2\pi a} dE \cos \theta$

$dE = \text{Electric field due to a small element having charge } dq$
 $= \frac{1}{4\pi\epsilon_0} \frac{dq}{r^2}$

Let $\lambda = \text{Linear charge density}$

$= \frac{dq}{dl}$
 $dq = \lambda dl$

Hence $E = \int_0^{2\pi a} \frac{1}{4\pi\epsilon_0} \cdot \frac{\lambda dl}{r^2} \times \frac{x}{r}$, where $\cos \theta = \frac{x}{r}$

$= \frac{\lambda x}{4\pi\epsilon_0 r^3} (2\pi a)$

$= \frac{1}{4\pi\epsilon_0} \frac{Qx}{(x^2+a^2)^{\frac{3}{2}}}$, where total charge $Q = \lambda \times 2\pi a$

At large distance i.e. $x \gg a$

$E \approx \frac{1}{4\pi\epsilon_0} \cdot \frac{Q}{x^2}$

This is the Electric field due to a point charge at distance x .

(NOTE: Award two marks for this question, if a student attempts this question but does not give the complete answer)

Set1,Q12
Set2,Q15
Set3,Q13

Three Characteristic features	1+1+1
-------------------------------	-------

The three characteristic features which can't be explained by wave theory are:

- i. Kinetic energy of emitted electrons are found to be independent of intensity of incident light.

Set1,Q16 Set2,Q13 Set3,Q17	<table border="1"> <tr> <td>Diagram showing attractive force on other wire.</td> <td>1</td> </tr> <tr> <td>Obtaining an expression for force.</td> <td>1</td> </tr> <tr> <td>Definition of one ampere.</td> <td>1</td> </tr> </table>	Diagram showing attractive force on other wire.	1	Obtaining an expression for force.	1	Definition of one ampere.	1		
Diagram showing attractive force on other wire.	1								
Obtaining an expression for force.	1								
Definition of one ampere.	1								
		1/2							
	<p>As shown in Figure, the direction of force on conductor b is attractive [Alternatively: \vec{B} at a point on wire 2, is along $-\hat{k}$ $\therefore \vec{F}$, on wire 2, due to the \vec{B}, is along $-\hat{i}$, i.e. towards wire 1. Hence the force is attractive.</p>	1/2							
	Magnetic field, due to current in conductor a,								
	$B_1 = \frac{\mu_0 I_1}{2\pi d}$	1/2							
	The magnitude of force on a length L of conductor b,								
	$F_2 = I_2 L B_1$	1/2							
	$F_2 = \frac{\mu_0 I_1 I_2 L}{2\pi d}$								
	One ampere is that steady current which, when maintained in each of the two very long, straight, parallel conductors, placed one meter apart in vacuum, would produce on each of these conductors a force equal to 2×10^{-7} newton per meter of their length.	1	3						
Set1,Q17 Set2,Q20 Set3,Q18	<table border="1"> <tr> <td>Production of em waves</td> <td>1</td> </tr> <tr> <td>Drawing of sketch of linearly polarized em waves</td> <td>1</td> </tr> <tr> <td>Indication of directions of oscillating electric and magnetic fields</td> <td>1/2 + 1/2</td> </tr> </table>	Production of em waves	1	Drawing of sketch of linearly polarized em waves	1	Indication of directions of oscillating electric and magnetic fields	1/2 + 1/2		
Production of em waves	1								
Drawing of sketch of linearly polarized em waves	1								
Indication of directions of oscillating electric and magnetic fields	1/2 + 1/2								
	A charge oscillating with some frequency, produces an oscillating electric field in space, which in turn produces an oscillating magnetic								

field perpendicular to the electric field, this process goes on repeating , producing em waves in space perpendicular to both the fields.

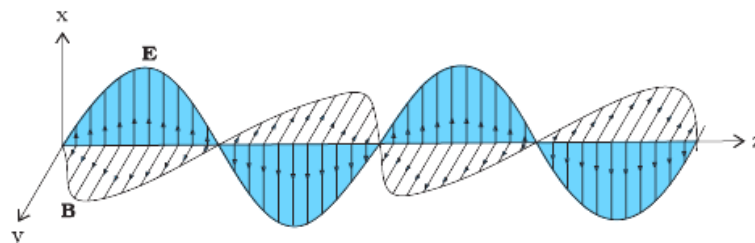

Directions of \vec{E} and \vec{B} are perpendicular to each other and also perpendicular to direction of propagation of em waves.

OR

Maxwell's generalization of Ampere's Circuital law	1
Showing that current produced, within the plates of a capacitor is $i = \epsilon_0 \frac{d\phi_\epsilon}{dt}$	2

Ampere's circuital law is given by as $\oint \vec{B} \cdot d\vec{l} = \mu_0 i_c$

But for a circuit containing capacitor, during its charging / discharging the current within the plates of the capacitor varies, (producing displacement current i_d). Therefore, the above equation, as generalized by Maxwell, is given as $\oint \vec{B} \cdot d\vec{l} = \mu_0 i_c + \mu_0 i_d$

During the process of charging of capacitor, electric flux (ϕ_ϵ) between the plates of capacitor changes with time, which produces the current within the plates of capacitor. This current, being proportional to $\frac{d\phi_\epsilon}{dt}$, we have

$$i = \epsilon_0 \frac{d\phi_\epsilon}{dt}$$

1

1

1/2 + 1/2

1

1

1

3

Set1,Q18
Set2,Q21
Set3,Q16

a) Explanation of any two factors justifying the need of modulation	1+ 1
b) Two advantages of FM over AM	1/2 + 1/2

a) A low frequency signal is modulated for the following purposes:
(i) It reduces the wavelength of transmitted signal, and the minimum height of antenna for effective communication is $\lambda/4$. Therefore height of antenna becomes practically achievable.

1

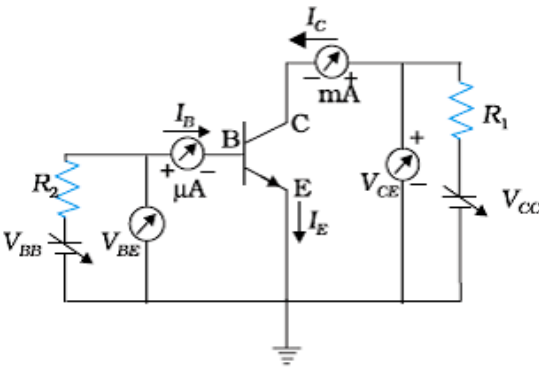
	<p>(ii) Power radiated into the space by an antenna is inversely proportional to λ^2. Therefore, the power radiated into the space increases and signal can travel larger distance. (Give full credit of this part for any other correct answer)</p> <p>b)</p> <p>(i) High efficiency (ii) Less noise (iii) Maximum use of transmitted power (any two)</p>	<p>1</p> <p>$\frac{1}{2} + \frac{1}{2}$</p>	<p>3</p>						
<p>Set1,Q19 Set2,Q22 Set3,Q20</p>	<table border="1" style="margin-left: auto; margin-right: auto;"> <tr> <td>(i) Function of three segments</td> <td>$\frac{1}{2} + \frac{1}{2} + \frac{1}{2}$</td> </tr> <tr> <td>(ii) Circuit diagram</td> <td>1</td> </tr> <tr> <td>Input and output characteristics</td> <td>$\frac{1}{2}$</td> </tr> </table> <p>i)</p> <p>Emitter : Supplies the large number of majority charge carriers for the flow of current through the transistor.</p> <p>Base : Controls the movement of charge carriers coming from emitter region</p> <p>Collector: Collects a major portion of the majority carriers supplied by the emitter.</p> <p>(NOTE: Also accept the following explanation of these parts of the transistor as asked in Hindi translation)</p> <p>Emitter: Heavily doped and of moderate size. Base: Central region, thin and lightly doped. Collector: Moderately doped and large sized.</p> <p>ii)</p>  <p>Input characteristics are obtained by recording the values of base current I_B, for different values of V_{BE} at constant V_{CE}</p> <p>Output characteristics are obtained by recording the values of I_C for different values of V_{CE} at constant I_B</p>	(i) Function of three segments	$\frac{1}{2} + \frac{1}{2} + \frac{1}{2}$	(ii) Circuit diagram	1	Input and output characteristics	$\frac{1}{2}$	<p>$\frac{1}{2}$</p> <p>$\frac{1}{2}$</p> <p>$\frac{1}{2}$</p> <p>1</p> <p>$\frac{1}{2}$</p>	
(i) Function of three segments	$\frac{1}{2} + \frac{1}{2} + \frac{1}{2}$								
(ii) Circuit diagram	1								
Input and output characteristics	$\frac{1}{2}$								

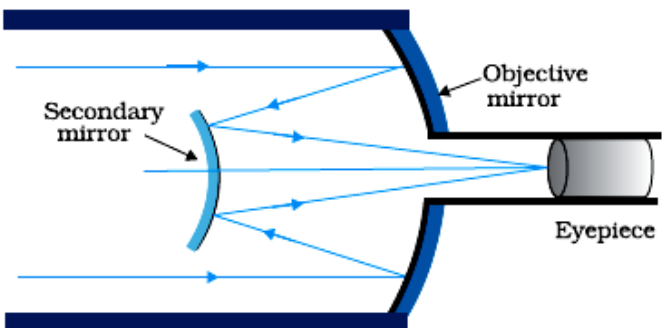
	<p>[Alternatively</p> $L = \frac{nh}{2\pi} \text{ i.e. angular momentum of orbiting electron is quantised.}]$ <p>According to de Broglie hypothesis Linear momentum (p) = $\frac{h}{\lambda}$ And for circular orbit $L = r_n p$ where 'r_n' is the radius of quantized orbits.</p> $= \frac{rh}{\lambda}$ <p>Also $L = \frac{nh}{2\pi}$</p> $\therefore \frac{rh}{\lambda} = \frac{nh}{2\pi}$ $\Rightarrow 2\pi r_n = n\lambda$ <p>\therefore Circumference of permitted orbits are integral multiples of the wavelength λ</p> <p>ii) $E_C - E_B = \frac{hc}{\lambda_1}$(i) $E_B - E_A = \frac{hc}{\lambda_2}$(ii)</p> $E_C - E_A = \frac{hc}{\lambda_3}$(iii) <p>Adding (i) & (ii)</p> $E_C - E_A = \frac{hc}{\lambda_1} + \frac{hc}{\lambda_2}$(iv) <p>Using equation (iii) and (iv)</p> $\frac{hc}{\lambda_3} = \frac{hc}{\lambda_1} + \frac{hc}{\lambda_2} \Rightarrow \frac{1}{\lambda_3} = \frac{1}{\lambda_1} + \frac{1}{\lambda_2}$	<p>1/2</p> <p>1/2</p> <p>1/2</p> <p>1/2</p> <p>1/2</p> <p>1/2</p> <p>1/2</p>	<p>3</p>
<p>Set1,Q22 Set2,Q19 Set3,Q21</p>	<p>Drawing of Schematic ray diagram Two advantages</p> 	<p>2</p> <p>1/2 + 1/2</p> <p>2</p>	

	<p>(i) Large gathering power (ii) Large magnifying power (iii) No chromatic aberration (iv) Spherical aberration is also removed (v) Easy mechanical support (vi) Large resolving power (Any Two)</p>	<p>$\frac{1}{2} + \frac{1}{2}$</p>	<p>3</p>
<p>Set1,Q23 Set2,Q23 Set3,Q23</p>	<p style="text-align: center;"><u>SECTION (D)</u></p> <div style="border: 1px solid black; padding: 5px; margin: 10px auto; width: fit-content;"> Answers of part (i) ,(ii), (iii) 1+1+2 </div> <p>(i) Values displayed by Meeta: Inquisitive/ Keen Observer/ Scientific temperament/ (Any other value.)</p> <p>Values displayed by Father: Encouraging/ Supportive /(Any other value)</p> <p>(ii) Meeta’s father explained that the traffic light is made up of tiny bulbs called light emitting diodes (LED) (Also accept other relevant answers)</p> <p>(iii)Light emitting diode</p> <p>These diodes (LED’s) operate under forward bias, due to which the majority charge carriers are sent from these majority zones to minority zones. Hence recombination occur near the junction boundary, which releases energy in the form of photons of light.</p>	<p>1</p> <p>1</p> <p>$\frac{1}{2}$</p> <p>$\frac{1}{2}$</p> <p>1</p>	<p>4</p>
	<p style="text-align: center;"><u>SECTION (E)</u></p>		
<p>Set1,Q24 Set2,Q25 Set3,Q26</p>	<div style="border: 1px solid black; padding: 10px;"> <p>(i) Obtaining expression for impedance & phase angle $1 \frac{1}{2} + 1$ Condition of current being in phase with voltage $\frac{1}{2}$ Naming of circuit condition $\frac{1}{2}$</p> <p>(ii) Calculation of P_1/P_2 $1 \frac{1}{2}$</p> </div> <div style="text-align: center; margin-top: 20px;"> </div>		

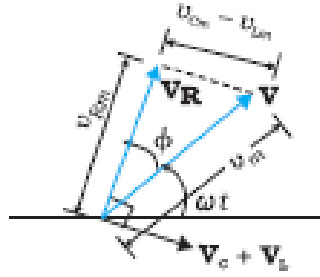

From Figure

$$\vec{V} = \vec{V}_L + \vec{V}_R + \vec{V}_C$$

$$\text{where } |\vec{V}_R| = i_m R$$

$$|\vec{V}_L + \vec{V}_C| = V_{Cm} - V_{Lm}$$

$$= i_m (X_C - X_L)$$

$$\Rightarrow V_m^2 = V_{Rm}^2 + (V_{Cm} - V_{Lm})^2$$

$$l_m^2 Z^2 = l_m^2 R^2 + i_m^2 (X_C - X_L)^2$$

$$\Rightarrow Z = \sqrt{R^2 + (X_C - X_L)^2}$$

From Figure

$$\tan \phi = \frac{V_{Cm} - V_{Lm}}{V_{Rm}} = \frac{i_m (X_C - X_L)}{i_m R}$$

$$\phi = \tan^{-1} \left(\frac{X_C - X_L}{R} \right)$$

Condition for current and voltage are in phase :

$$V_L = V_C \text{ or } X_L = X_C$$

Circuit is called Resonant circuit.

$$\text{ii) Power factor } P_1 = \frac{R}{Z} = \frac{R}{\sqrt{R^2 + R^2}} = \frac{1}{\sqrt{2}}$$

(as $X_L = R$)

Power factor when capacitor C of Reactance $X_C = X_L$ is put in series in the circuit

1/2

1/2

1/2

1/2

1/2

1/2

1/2

1/2

$$P_2 = \frac{R}{Z} = \frac{R}{R} = 1$$

as $Z=R$ at resonance

$$\therefore \frac{P_1}{P_2} = \frac{1}{\sqrt{2}} = \frac{1}{\sqrt{2}}$$

OR

(i)	Function of transformer	1/2
	Working principle and diagram	1/2 + 1/2
	Various energy losses (two)	1/2 + 1/2
(ii)	Calculation of part (a) , (b), (c), (d) & (e)	2 1/2

(i) Conversion of ac of low voltage into ac of high voltage & vice versa

Mutual induction: When alternating voltage is applied to primary windings, emf is induced in the secondary windings.

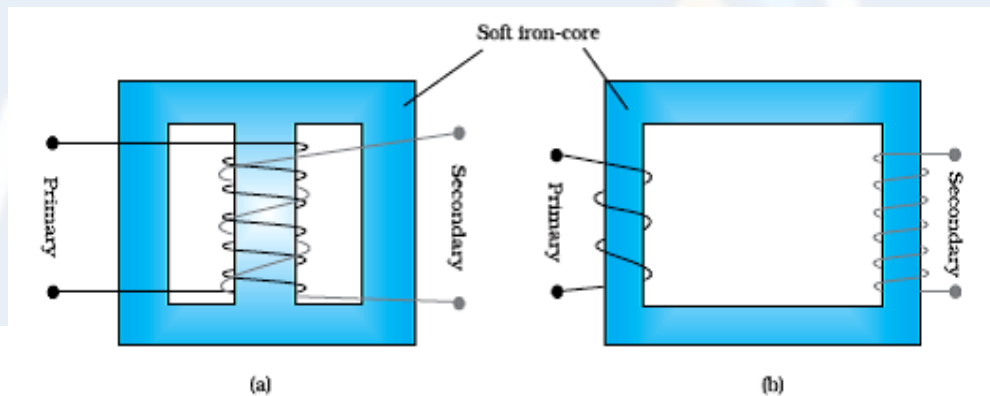

(Any one of the above diagram)

Energy losses:

- a. Leakage of magnetic flux
- b. Eddy currents
- c. Hysterisis loss
- d. Copper loss

(Any two)

ii)

$$N_p = 100$$

Transformation ratio= 100

a) Number of turns in secondary coil

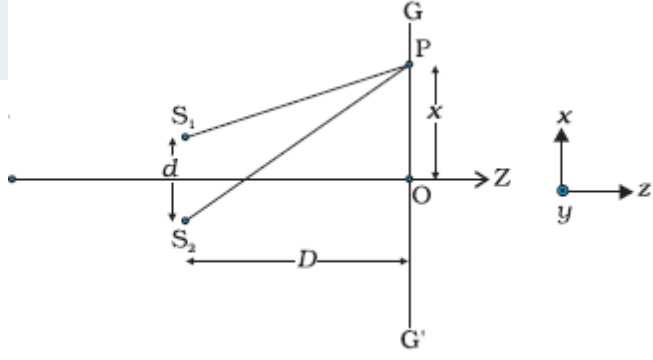
	<p>$N_s = 100 \times 100 = 10000$</p> <p>b) Input Power = Input voltage x current in primary $1100 = 220 \times I_p$ $\Rightarrow I_p = 5A$</p> <p>c) $\frac{V_s}{V_p} = \frac{N_s}{N_p}$ $\frac{V_s}{220} = 100$ $\Rightarrow V_s = 2.2 \times 10^4$ volts</p> <p>d) $\frac{I_p}{I_s} = \frac{N_s}{N_p}$ $\frac{5}{I_s} = 100$ $\Rightarrow I_s = \frac{5}{100} = 0.05$ A</p> <p>e) Power in secondary = Power in Primary $= 1100$ W</p>	<p>$\frac{1}{2}$</p> <p>$\frac{1}{2}$</p> <p>$\frac{1}{2}$</p> <p>$\frac{1}{2}$</p> <p>$\frac{1}{2}$</p>	<p></p> <p></p> <p></p> <p></p> <p>5</p>
<p>Set1,Q25 Set2,Q26 Set3,Q25</p>	<div style="border: 1px solid black; padding: 10px; margin-bottom: 10px;"> <p>i) Deduce the conditions for a) constructive and b) destructive interference 2 $\frac{1}{2}$</p> <p>Graph showing the variation of intensity 1</p> <p>ii) Three distinguishing features 1 $\frac{1}{2}$</p> </div> <p>i)</p>  <p>From figure Path difference = $(S_2P - S_1P)$</p> $(S_2P)^2 - (S_1P)^2 = [D^2 + (x + \frac{d}{2})^2] - [D^2 + (x - \frac{d}{2})^2]$ $(S_2P + S_1P)(S_2P - S_1P) = 2xd$	<p>$\frac{1}{2}$</p>	<p></p>

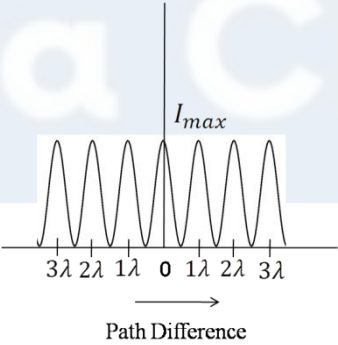
	$S_2P - S_1P = \frac{2xd}{S_2P + S_1P}$ <p>For $x, d \ll D$ $S_2P + S_1P = 2D$</p> $\therefore S_2P - S_1P = \frac{2xd}{2D} = \frac{xd}{D}$ <p>For constructive interference $S_2P - S_1P = n\lambda, n=0,1,2,\dots$</p> $\Rightarrow \frac{xd}{D} = n\lambda$ $\Rightarrow x = \frac{n\lambda D}{d}$ <p>For destructive interference $S_2P - S_1P = (2n + 1)\frac{\lambda}{2}$ $n=0, 1, 2, \dots$</p> $\frac{xd}{D} = (2n + 1)\frac{\lambda}{2}$ $\Rightarrow x = (2n + 1)\frac{\lambda D}{2d}$ <div style="text-align: center;">  </div> <p>ii)</p> <p>(a) The Interference pattern has number of equally spaced bright and dark bands, while in the diffraction pattern the width of the central maximum is twice the width of other maxima.</p> <p>(b) In Interference all bright fringes are of equal intensity, whereas in the diffraction pattern the intensity falls as order of maxima increases.</p> <p>(c) In Interference pattern, maxima occurs at an angle $\frac{\lambda}{a}$, where a is the slit width, whereas in diffraction pattern, at the same angle, first minimum occurs. (Here 'a' is the size of the slit)</p> <p>(Any other distinguishing feature)</p>	<p>$\frac{1}{2}$</p> <p>$\frac{1}{2}$</p> <p>$\frac{1}{2}$</p> <p>$\frac{1}{2}$</p> <p>1</p> <p>$\frac{1}{2}$</p> <p>$\frac{1}{2}$</p> <p>$\frac{1}{2}$</p>	<p></p> <p></p> <p></p> <p></p> <p></p> <p></p> <p>5</p>
--	---	--	--

OR

- | | | |
|------|--|-------|
| i) | Plot showing the variation of the angle of deviation as a function of angle of incidence | 1 |
| | Derivation of expression of refractive index | 1 ½ |
| ii) | Definition of Dispersion and its cause | ½ + ½ |
| iii) | Calculation of minimum value of refractive index | 1 ½ |

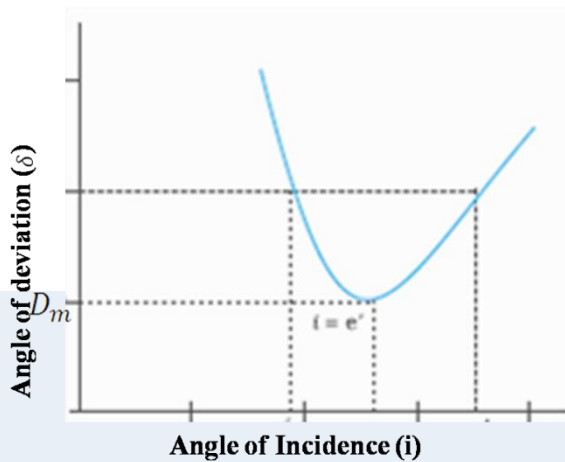

From figure $\delta = D_m, i = e$ which implies $r_1 = r_2$

$$2r = A, \text{ or } r = A/2$$

Using $\delta = i + e - A$

$$D_m = 2i - A$$

$$i = \frac{A + D_m}{2}$$

$$\mu = \frac{\sin i}{\sin r} = \frac{\sin\left(\frac{A + D_m}{2}\right)}{\sin A/2}$$

- (ii) The phenomenon of splitting of white light into its constituent colours.

Cause: Refractive index of the material is different for different colours
According to the equation, $\delta \neq (\mu - 1)A$, where A is the angle of prism, different colours will deviate through different amount.

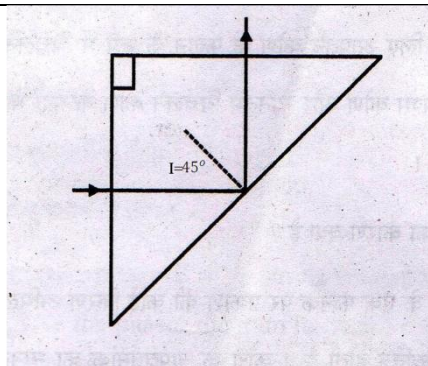

For total internal reflection,
 $\angle i \geq \angle i_c$ (critical angle)

$$\Rightarrow 45^\circ \geq \angle i_c, \text{ i.e., } \angle i_c \leq 45^\circ$$

$$\sin i_c \leq \sin 45^\circ$$

$$\leq \frac{1}{\sqrt{2}}$$

$$\frac{1}{\sin i_c} \geq \sqrt{2}$$

$$\Rightarrow \mu \geq \sqrt{2}$$

Hence, the minimum value of refractive index must be $\sqrt{2}$

1/2

1/2

1/2

5

Set1,Q26
 Set2,Q24
 Set3,Q24

i)	Definition of drift velocity	1
ii)	Derivation of expression of resistivity	2
	Factors affecting resistivity	1
iii)	Reason of using constantan and manganin	1

i) Average velocity acquired by the electrons in the conductor in the presence of external electric field.

[Alternatively:

$$v_d = \frac{-eE\tau}{m} \text{ where } \tau \text{ is the relaxation time.}]$$

ii) $v_d = \frac{-eE\tau}{m}$

We have $E = -\frac{V}{\ell}$, where V is potential difference across the length ' ℓ ' of the conductor

$$v_d = \frac{eV\tau}{m\ell}$$

Current flowing $I = neAv_d$

$$I = neAv_d \frac{eV\tau}{m\ell} = \frac{ne^2AV\tau}{m\ell}$$

$$\frac{I}{V} = \frac{ne^2A\tau}{m\ell} = \frac{1}{R} \text{ -----(i)}$$

1

1/2

1/2

1/2

	<p>Also, $R = \rho \frac{l}{A}$ -----(ii)</p> <p>Comparing (i) and (ii)</p> $\rho = \frac{m}{ne^2\tau}$ <p>Resistivity of the material of a conductor depends on the relaxation time, i.e., temperature and the number density of electrons.</p> <p>iii) Because constantan and manganin show very weak dependence of resistivity on temperature</p> <p style="text-align: center;">OR</p> <table border="1" style="width: 100%; border-collapse: collapse;"> <tbody> <tr> <td style="width: 50%;">i) Working Principle of potentiometer</td> <td style="width: 50%; text-align: right;">2</td> </tr> <tr> <td>ii) Calculation of potential gradient and balance length</td> <td style="text-align: right;">3</td> </tr> </tbody> </table> <p>i) When constant current flows through a conductor of uniform area of cross section, the potential difference, across a length l of the wire, is directly proportional to that length of the wire. $[V \propto l \text{ (Provided current and area are constant)}]$</p> <p>ii) Current flowing in the potentiometer wire</p> $i = \frac{E}{R_{total}} = \frac{2.0}{15 + 10} = \frac{2}{25} \text{ A}$ <p>\therefore Potential difference across the two ends of the wire</p> $V_{AB} = \frac{2}{25} \times 10V = \frac{20}{25} = 0.8 \text{ volt}$ <p>Hence potential gradient $K = \frac{V_{AB}}{l_{AB}} = \frac{0.8}{1.0} = 0.8 \text{ V/m}$</p> <p>Current flowing in the circuit containing experimental cell,</p> $= \frac{1.5}{1.2 + 0.3} = 1 \text{ A}$ <p>Hence, potential difference across length AO of the wire</p> $= 0.3 \times 1V = 0.3V$ $\Rightarrow 0.3 = K \times l_{AO}$ $= 0.8 \times l_{AO}$ $\Rightarrow l_{AO} = \frac{0.3}{0.8} \text{ m} = 0.375 \text{ m}$ $= 37.5 \text{ cm}$	i) Working Principle of potentiometer	2	ii) Calculation of potential gradient and balance length	3	<p>$\frac{1}{2}$</p> <p>$\frac{1}{2} + \frac{1}{2}$</p> <p>1</p> <p>2</p> <p>$\frac{1}{2}$</p> <p>$\frac{1}{2}$</p> <p>$\frac{1}{2}$</p> <p>$\frac{1}{2}$</p> <p>$\frac{1}{2}$</p> <p>$\frac{1}{2}$</p>	<p>5</p> <p>5</p>
i) Working Principle of potentiometer	2						
ii) Calculation of potential gradient and balance length	3						