

## Physics Delhi (Set 2)

---

### General Instructions:

**Read the following instructions very carefully and strictly follow them:**

- (i) This question paper comprises **four** sections – A, B, C and D.
- (ii) There are **37** questions in the question paper. **All** questions are compulsory.
- (iii) Section A : Q. no. **1** to **20** are very short-answer type questions carrying **1** mark each.
- (iv) Section B : Q. no. **21** to **27** are short-answer type questions carrying 2 marks each.
- (v) Section C : Q. no. **28** to **34** are long-answer type questions carrying 3 marks each.
- (vi) Section D : Q. no. **35** to **37** are also long answer type questions carrying **5** marks each.
- (vii) There is no overall choice in the question paper. However, an internal choice has been provided in **two** questions of **one** mark, **two** questions of **two** marks, **one** question of **three** marks and all the **three** questions of **five** marks. You have to attempt **only one** of the choices in such questions.
- (viii) However, separate instructions are given with each section and question, wherever necessary.
- (ix) Use of calculators and log tables is not permitted.
- (x) You may use the following values of physical constants wherever necessary.

$$c = 3 \times 10^8 \text{ m/s}$$

$$h = 6.63 \times 10^{-34} \text{ Js}$$

$$e = 1.6 \times 10^{-19} \text{ C}$$

$$\mu_0 = 4\pi \times 10^{-7} \text{ T m A}^{-1}$$

$$\epsilon_0 = 8.854 \times 10^{-12} \text{ C}^2 \text{ N}^{-1} \text{ m}^{-2}$$

$$\frac{1}{4\pi\epsilon_0}$$

$$= 9 \times 10^9 \text{ N m}^2 \text{ C}^{-2}$$

$$\text{Mass of electron } (m_e) = 9.1 \times 10^{-31} \text{ kg}$$

$$\text{Mass of neutron} = 1.675 \times 10^{-27} \text{ kg}$$

$$\text{Mass of proton} = 1.673 \times 10^{-27} \text{ kg}$$

$$\text{Avogadro's number} = 6.023 \times 10^{23} \text{ per gram mole}$$

$$\text{Boltzmann constant} = 1.38 \times 10^{-23} \text{ JK}^{-1}$$

### Question 1

The wavelength and intensity of light emitted by a LED depend upon

- (a) forward bias and energy gap of the semiconductor
- (b) energy gap of the semiconductor and reverse bias
- (c) energy gap only
- (d) forward bias only

**Solution:**

The wavelength and intensity of light emitted by an LED depends on both energy gap and bias of the diode. Only when the diode is forward biased, it emits photons. The wavelength of the emitted light depends on the energy gap of the semiconductor.

Hence, the correct answer is option (a).

**Question 2**

The graph showing the correct variation of linear momentum ( $p$ ) of a charge particle with its de-Broglie wavelength ( $\lambda$ ) is -

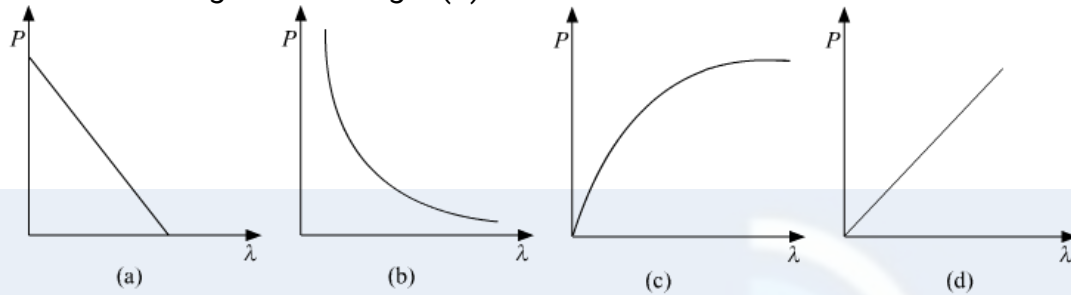
**Solution:**

The relation between de-Broglie wavelength and the momentum is:

$$\lambda = \frac{h}{p}$$
$$\Rightarrow p = \frac{h}{\lambda}$$

By the above relation, we can conclude that the graph between the momentum and the de-Broglie wavelength is a rectangular hyperbola.

Hence, the correct answer is option (b).

**Question 3**

The selectivity of a series LCR a.c. circuit is large, when

- (a)  $L$  is large and  $R$  is large
- (b)  $L$  is small and  $R$  is small
- (c)  $L$  is large and  $R$  is small
- (d)  $L = R$

**Solution:** Selectivity of a circuit depends on the quality of resonance. The quality factor is given by:

$$Q = \frac{\omega_0 L}{R}$$

High value of quality factor make sure that the resonance curve is sharp. Sharper the resonance curve is more selective is the LCR circuit. Thus, the selectivity of the LCR circuit is large when  $L$  is large and  $R$  is small.

Hence, the correct answer is option (c).

#### Question 4

Photo diodes are used to detect

- (a) radio waves
- (b) gamma rays
- (c) IR rays
- (d) optical signals

**Solution:** Photodiodes are used to detect the visible light, out of the given options optical signals is the most appropriate.

Hence, the correct answer is option (d).

#### Question 5

The relationship between Brewster angle  $\theta$  and speed of light  $v$  in the denser medium is

- (a)  $c \cos\theta = v$
- (b)  $v \tan\theta = c$
- (c)  $c = v \tan\theta$
- (d)  $v \cos\theta = c$

**Solution: Disclaimer:** Two of the given option (b and c) are same.

Let the absolute refractive index of the given medium be  $\mu$  and the speed of light in vacuum be  $c$ .

From Brewster's law:

$$\tan \theta = \mu$$

The refractive index can also be written as:

$$\mu = \frac{c}{v}$$

$$\Rightarrow \tan \theta = \frac{c}{v}$$

$$\Rightarrow c = v \tan \theta$$

Hence, the correct answer is option (b).

### Question 6

A biconvex lens of focal length  $f$  is cut into two identical plano-convex lenses. The focal length of each part will be

- (a)  $f$
- (b)  $f/2$
- (c)  $2f$
- (d)  $4f$

#### Solution:

Let the focal of the equiconvex lens be  $f$  and that of the plano-convex lens be  $f'$ .

Let the radius of curvature for the equiconvex lens be  $R$ .

Applying Lens maker's formula

$$\frac{1}{f} = (\mu - 1) \left( \frac{1}{R} + \frac{1}{R} \right) = \frac{2(\mu - 1)}{R}$$

For the plano-convex lens, the focal length can be calculated as:

$$\frac{1}{f'} = (\mu - 1) \left( \frac{1}{R} \right) = \frac{(\mu - 1)}{R}$$

Thus,  $f' = 2f$

Thus, the focal length of the plano-convex lens is twice that of the equiconvex lens.

Hence, the correct answer is option (c)

### Question 7

The phase difference between the current and the voltage in series LCR circuit at resonance is

- (a)  $\pi$
- (b)  $\pi/2$
- (c)  $\pi/3$
- (d) zero

**Solution:**

At resonance the circuit is purely resistive and there is no phase difference between current and voltage.

Hence, the correct answer is option (d).

**Question 8**

Photons of frequency  $\nu$  are incident on the surface of two metals A and B of threshold frequency  $\frac{3}{4}\nu$  and  $\frac{2}{3}\nu$ , respectively. The ratio of maximum kinetic energy of electrons emitted from A to that from B is

- (a) 2 : 3
- (b) 4 : 3
- (c) 3 : 4
- (d) 3 : 2

**Solution:**

According to Einstein's photoelectric equation,

$$h\nu = h\nu_0 + K_{\max}$$

Where,

$\nu$  = frequency of the incident light

$\nu_0$  = threshold frequency of the metal

$K_{\max}$  = maximum kinetic energy of the emitted photoelectrons

For the first metal,

$$h\nu = h\left(\frac{3}{4}\nu\right) + K_1$$

$$\Rightarrow K_1 = \frac{h\nu}{4}$$

For the second metal,

$$h\nu = h\left(\frac{2}{3}\nu\right) + K_2$$

$$\Rightarrow K_2 = \frac{h\nu}{3}$$

Thus, the ratio of the maximum kinetic energies is given as:

$$\frac{K_1}{K_2} = \frac{3}{4}$$

Hence, the correct answer is option (c).

### Question 9

The electric flux through a closed Gaussian surface depends upon

- (a) Net charge enclosed and permittivity of the medium
- (b) Net, charge enclosed, permittivity of the medium and the size of the Gaussian surface
- (c) Net charge enclosed only
- (d) Permittivity of the medium only

### Solution:

The electric flux through a closed Gaussian surface is given by:

$$\oint \vec{E} \cdot d\vec{s} = \frac{q}{\epsilon}$$

Where,  $q$  is the net charge enclosed by the Gaussian and  $\epsilon$  is the permittivity of the medium.

Hence, the correct answer is option (a).

### Question 10

A charge particle after being accelerated through a potential difference ' $V$ ' enters in a uniform magnetic field and moves in a circle of radius  $r$ . If  $V$  is doubled, the radius of the circle will become

- (a)  $2r$
- (b)  $\sqrt{2}r$
- (c)  $4r$
- (d)  $r/\sqrt{2}$

**Solution:** The relation between the accelerating potential and the accelerating voltage is given as:

$$r = \frac{\sqrt{2mqV}}{qB}$$

As the potential is doubled the radius of curvature becomes  $2-\sqrt{2}$  times.

Hence, the correct answer is option (b).

### Question 11

A point charge is placed at the centre of a hollow conducting sphere of internal radius ' $r$ ' and outer radius ' $2r$ '. The ratio of the surface charge density of the inner surface to that of the outer surface will be\_\_\_\_\_.

#### Solution:

Let the point charge be  $q$ .

by gauss's law the charge on the inner surface will be  $-q$

Surface charge density of the inner surface  $\sigma_i = -\frac{q}{4\pi r^2}$

by charge conservation on the hollow sphere the outer surface will have charge  $q$

Surface charge density of the outer surface  $\sigma_o = \frac{q}{4\pi(2r)^2} = \frac{q}{16\pi r^2}$

$$\text{ratio} = \frac{\sigma_i}{\sigma_o} = \frac{-\frac{q}{4\pi r^2}}{\frac{q}{16\pi r^2}} = -\frac{4}{1}$$

### Question 12

The \_\_\_\_\_, a property of materials C, Si and Ge depends upon the energy gap between their conduction and valence bands.

**Solution:** Conductivity

### Question 13

The ability of a junction diode to \_\_\_\_\_ an alternating voltage, is based on the fact that it allows current to pass only when it is forward biased.

**Solution:** Rectify

### Question 14

The physical quantity having SI unit  $\text{NC}^{-1}\text{m}$  is \_\_\_\_\_.

#### Solution:

Electric Potential.

### Question 15

A copper wire of non-uniform area of cross-section is connected to a d.c. battery. The physical quantity, which remains constant along the wire is \_\_\_\_\_.

**Solution:** Electric current.

### Question 16

Write the conditions on path difference under which (i) constructive (ii) destructive interference occur in Young's double slit experiment.

#### Solution:

$I_1$  = intensity of light from slit 1

$I_2$  = intensity of light from slit 2

phase difference between 2 light waves =  $\theta = \frac{2\pi\Delta x}{\lambda}$ , where  $\Delta x$  = path difference  
resultant intensity  $I$  is given by,

$$I = I_1 + I_2 + 2\sqrt{I_1 I_2} \cos \theta$$

for constructive interference  $I$  should be maximum  $\Rightarrow \cos \theta = 1$

$$\theta = 2n\pi, n = \text{Integer}$$

$$2n\pi = \frac{2\pi\Delta x}{\lambda}$$

$$\Delta x = n\lambda$$

for destructive interference  $I$  should be minimum  $\Rightarrow \cos \theta = -1$

$$\theta = (2n + 1)\pi, n = \text{Integer}$$

$$2n\pi = \frac{(2n+1)\pi\Delta x}{\lambda}$$

$$\Delta x = \frac{(2n+1)\lambda}{2}$$

### Question 17

Plot a graph showing variation of induced e.m.f. with the rate of change of current flowing through a coil.

OR

A series combination of an inductor ( $L$ ), capacitor ( $C$ ) and a resistor ( $R$ ) is connected across an ac source of emf of peak value  $E_0$ , and angular frequency ( $\omega$ ). Plot a graph to show variation of impedance of the circuit with angular frequency ( $\omega$ ).

#### Solution:

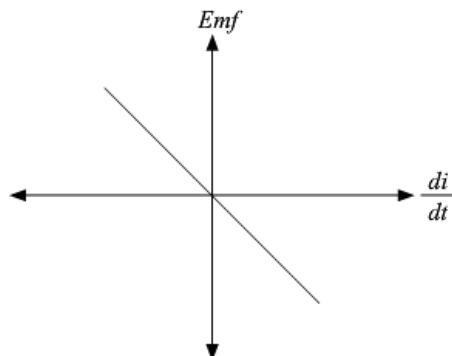



OR

The graph showing the variation of impedance ( $Z$ ) of the circuit with angular frequency ( $\omega$ ) is as shown below:

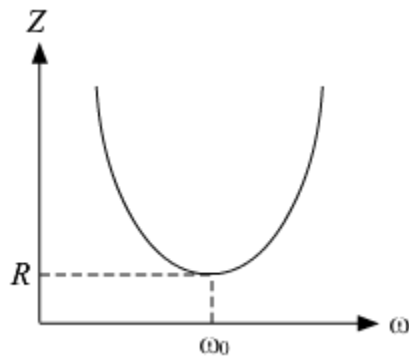

Here,  $\omega_0$  represents the resonance frequency for the LCR circuit and  $R$  is the resistance of the circuit.

### Question 18

Depict the fields diagram of an electromagnetic wave propagating along positive X-axis with its electric field along Y-axis.

**Solution:**

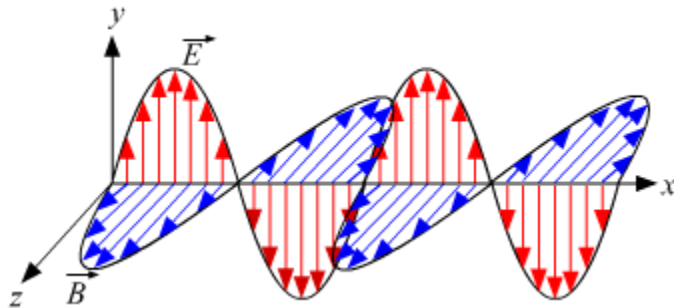

### Question 19

An electron moves along +x direction. It enters into a region of uniform magnetic field.

$\vec{B}$  directed along  $-z$  direction as show in fig. Draw the shape of trajectory followed by the electron after entering the field.

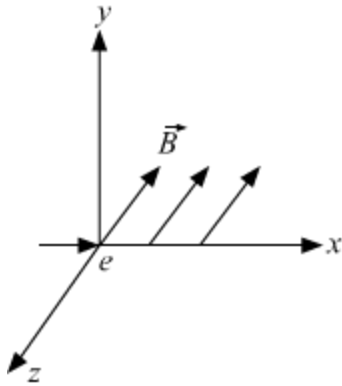

**OR**

A square shaped current carrying loop MNOP is placed near a straight long current carrying wire AB as shown in the fig. The wire and the loop lie in the same plane. If the loop experiences a net force  $F$  towards the wire, find the magnitude of the force on the side 'NO' of the loop.

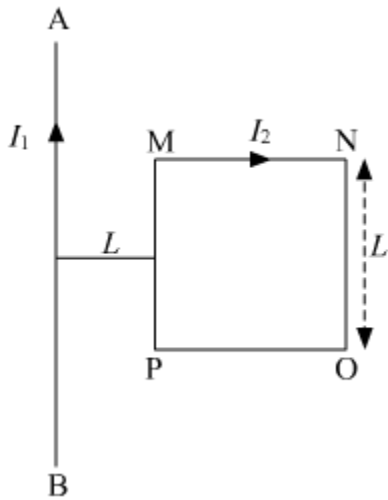

**Solution:**

Force on the electron is given by

$$\vec{F} = -q(\vec{v} \times \vec{B})$$

So, the electron will follow a semi circular path in the magnetic field.

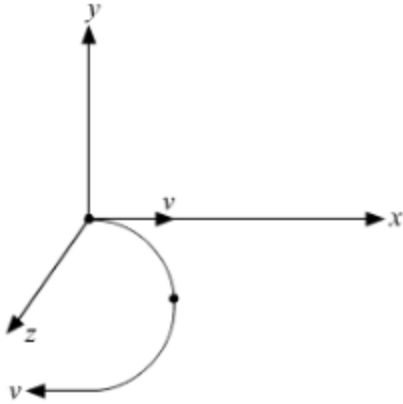

The force acting on the section MN and force on section PO will cancel as the wires are located at equal distance from the infinite wire but have current flowing in opposite directions.

The force acting on the whole loop,

$$F = \frac{\mu_0 I_1 I_2 L}{2\pi L} - \frac{\mu_0 I_1 I_2 L}{2\pi(2L)} = \frac{\mu_0 I_1 I_2 L}{4\pi L}$$

Towards the wire.

The force acting on the side 'NO' is given by

$$F_{NO} = \frac{\mu_0 I_1 I_2}{2\pi(2L)} L = \frac{\mu_0 I_1 I_2}{4\pi} = F$$

Away from the wire.

### Question 20

Define the term 'current sensitivity' of a moving coil galvanometer.

#### Solution:

Current sensitivity of a galvanometer is defined as the deflection produced in the galvanometer when a unit current flows through it.

Mathematically it can be given by:

$$I_S = \frac{NBA}{k}$$

where  $k$  is the couple per unit twist.

### Question 21

- (a) Define one Bacquerel.
- (b) A radioactive substance disintegrates into two types of daughter nuclei, one type with disintegration constant  $\lambda_1$  and the other type with disintegration constant  $\lambda_2$ . Determine the half-life of the radioactive substance.

#### Solution:

a) One Becquerel (Bq) is defined as the activity of a quantity of radioactive sample in which one nucleus decays per second. It is the S.I. unit of the activity.

b)

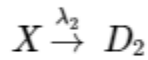
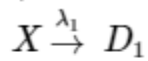

$$\lambda_{\text{effective}} = \lambda_1 + \lambda_2$$

$$\text{half life } \left( t_{1/2} \right) = \frac{\ln 2}{\lambda_{\text{effective}}} = \frac{0.693}{\lambda_1 + \lambda_2}$$

### Question 22

In a single slit diffraction experiment, the width of the slit is increased. How will the (i) size and (ii) intensity of central bright band be affected? Justify your answer.

**Solution:** The size of the central maximum is given by  $2\lambda/a$  where  $a$  is the slit width. It is clear from the above expression if  $a$  is increased, the size of the central maximum will decrease.

However, the intensity changes because of two factors.

1. Increasing the width of the slit, causes more light energy to fall on the screen as compared to that with the original width.
2. The light energy is now squeezed into a smaller area on the screen because the size of the central maximum is reduced. The two factors make the intensity increase manyfold.

### Question 23

- In case of photo electric effect experiment, explain the following facts, giving reasons.
- (a) The wave theory of light could not explain the existence of the threshold frequency.
- (b) The photo electric current increases with increase of intensity of incident light.

**Solution:**

(a) If light were strictly a wave, the energy in the light would be represented by the amplitude of the light wave. A more intense light source, even if it were of a lower frequency, would have enough energy to knock out electrons away from the metal surface, which is necessary to generate a photoelectric current.

What actually occurs is that the light below a certain threshold frequency does not generate any current, no matter how intense the light is.

(b) The intensity represents the number of photons, if the frequency of the incident light is more than the threshold frequency then more intensity will make ensure that more number of photons are falling over the metal surface and more photoelectrons will be emitted that increases the photoelectric current.

**Question 24**

Gamma rays and radio waves travel with the same velocity in free space. Distinguish between them in terms of their origin and the main application.

**Solution:**

Gamma rays are produced from radioactive decay of the nucleus while radio waves are produced from rapid acceleration and decelerations of electrons in aerials.

Gamma rays are used as catalyst in the manufacturing of some chemicals. They are also used in treatment of cancer.

Radio waves are used in radio and television communication and broadcasting.

**Question 25**

Use Bohr's model of hydrogen atom to obtain the relationship between the angular momentum and the magnetic moment of the revolving electron.

**Solution:**

According to Bohr's second postulate of the allowed values of angular momentum are integral multiples of  $h/2\pi$ .

Let  $n$  be the principal quantum number,  $r_n$  be the radius of  $n$ th possible orbit and  $v_n$  be the speed of moving electron in  $n^{\text{th}}$  orbit

$$L_n = m_n v_n r_n = \frac{nh}{2\pi}$$

magnetic moment,  $\mu = \text{current} \times \text{area}$

$$\mu = \frac{e}{T} \times \pi r_n^2 = \frac{e v_n}{2\pi r_n} \times \pi r_n^2 = \frac{e v_n r_n}{2} = \frac{e m v_n r_n}{2m} = \frac{e L_n}{2m}$$

$$\text{or } \mu = \frac{eL}{2m}$$

### Question 26

Define the term 'wave front of light'. A plane wave front AB propagating from denser medium (1) into a rarer medium (2) is incident on the surface P<sub>1</sub>P<sub>2</sub> separating the two media as shown in fig.

Using Huygen's principle, draw the secondary wavelets and obtain the refracted wave front in the diagram.

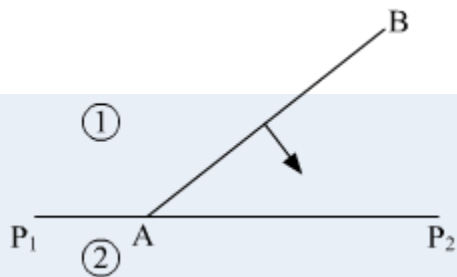

OR

Light from a sodium lamp (S) passes through two polaroid sheets P<sub>1</sub> and P<sub>2</sub> as shown in fig. What will be the effect on the intensity of the light transmitted (i) by P<sub>1</sub> and (ii) by P<sub>2</sub> on the rotating polaroid P<sub>1</sub> about the direction of propagation of light? Justify your answer in both cases.

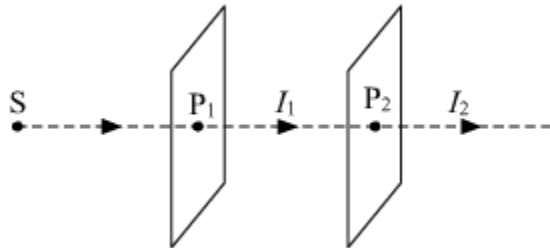

**SOLUTION:** It is defined as the locus of all the particles of a medium vibrating in the same phase at a given instant of time.

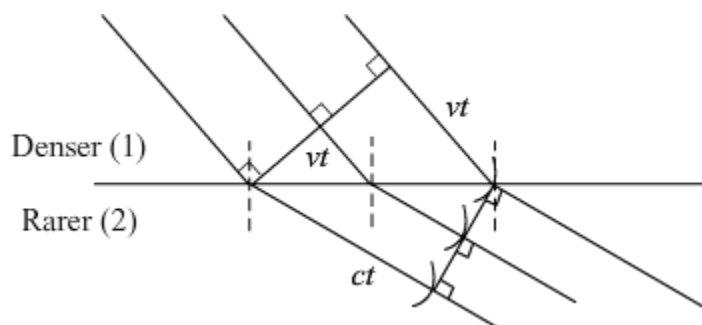

(i) There is no change in  $I_1$  on rotation of  $P_1$ , because the intensity of light does not change irrespective of the orientation of pass-axis of the polaroid.

(ii)  $I_1$  = intensity of polarised light from  $P_1$

$I_2$  = intensity of polarised light from  $P_2$

$\theta$  = Angle between pass axis of polaroid  $P_1$  and  $P_2$

by Malus's Law,  $I_2 = I_1 \cos^2 \theta$

Thus  $I_2$  changes when  $P_1$  is rotated as  $\theta$  changes

$I_2 = 0$ , when  $\theta = 90^\circ$

$I_2 = I_1$ , when  $\theta = 0^\circ$

### Question 27

Obtain the expression for the energy stored in a capacitor connected across a dc battery. Hence define energy density of the capacitor.

OR

Derive the expression for the torque acting on an electric dipole, when it is held in a uniform electric field. Identify the orientation of the dipole in the electric field, in which it attains a stable equilibrium.

**SOLUTION:** Energy Stored in a Charged Capacitor

The energy of a charged capacitor is measured by the total work done in charging the capacitor to a given potential.

Let us assume that initially both the plates are uncharged. Now, we have to repeatedly remove small positive charges from one plate and transfer them to the other plate.

Let

$q \rightarrow$  Total quantity of charge transferred

$V \rightarrow$  Potential difference between the two plates

Then,

$$q = CV$$

Now, when an additional small charge  $dq$  is transferred from the negative plate to the positive plate, the small work done is given by,

$$dW = Vdq = \frac{q}{C} dq$$

The total work done in transferring charge  $Q$  is given by,

$$W = \int_0^Q \frac{q}{C} dq = \frac{1}{C} \int_0^Q q dq = \frac{1}{C} \left[ \frac{q^2}{2} \right]_0^Q$$

$$\boxed{W = \frac{Q^2}{2C}}$$

This work done is stored as electrostatic potential energy  $U$  in the capacitor.

$$U = \frac{Q^2}{2C}$$

Hence energy stored in the capacitor =  $\frac{1}{2} \frac{Q^2}{C} = \frac{(A\sigma)^2}{2} \times \frac{d}{\epsilon_0 A}$

The surface charge density  $\sigma$  is related to the electric field  $E$  between the plates,  $E = \frac{\sigma}{\epsilon_0}$

So, energy stored in the capacitor =  $\frac{1}{2} \epsilon_0 E^2 \times Ad$

Here,  $Ad$  is volume between the plates of capacitor.

We define energy density as energy stored per unit volume of space.

Energy density of electric field =  $U = \frac{1}{2} \epsilon_0 E^2$

OR

### Dipole in a Uniform External Field

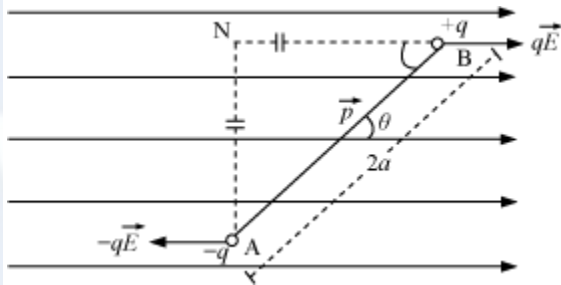

Consider an electric dipole consisting of charges  $-q$  and  $+q$  and of length  $2a$  placed in a uniform electric field  $\vec{E}$  making an angle  $\theta$  with the electric field.

Force on charge  $-q$  at  $A = -q\vec{E}$  (opposite to  $\vec{E}$ )

Force on charge  $+q$  at  $B = q\vec{E}$  (along  $\vec{E}$ )

The Electric dipole is under the action of two equal and unlike parallel forces, which give rise to a torque on the dipole.

$\tau = \text{Force} \times \text{Perpendicular distance between the two forces}$

$$\tau = qE (AN) = qE (2a \sin \theta)$$

$$\tau = q(2a) E \sin \theta$$

$$\tau = pE \sin \theta$$

$$\therefore \vec{\tau} = \vec{p} \times \vec{E}$$



In a uniform electric field, the net force on dipole will always be zero but torque is zero for  $\theta = 0^\circ$  and  $\theta = 180^\circ$

Now Potential Energy of a dipole in a uniform external electric field is given by the

expression  $P \cdot E = -\vec{p} \cdot \vec{E}$

1. For  $\theta = 0^\circ$ ,  $U = -pE$  (minimum), the equilibrium will be stable and if the dipole is slightly displaced, it performs oscillations.

2. For  $\theta = 180^\circ$ ,  $U = +pE$  (maximum), it will be an unstable equilibrium.

**Question:**

(a) Two point charges  $q_1$  and  $q_2$  are kept at a distance of  $r_{12}$  in air. Deduce the expression for the electrostatic potential energy of this system.

(b) If an external electric field ( $E$ ) is applied on the system, write the expression for the total energy of this system.

**SOLUTION:**

(a) Electrostatic potential energy of a system is defined as the total amount of the work done in bringing the various charges to their respective position from infinitely large mutual separation.

Let us consider a charge  $q_1$  at a position vector  $r_1$  and  $q_2$  at infinity which is to be brought at point  $P_2$  having position vector  $r_2$ . and  $dW$  is the small amount of work done in moving a charge to a distance  $dx$ .

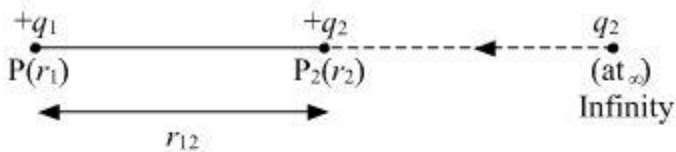

$$dW = \vec{F} \cdot d\vec{x}$$

$$dW = -\frac{kq_1q_2}{r^2} \cdot dx$$

$$W = -\int_{\infty}^{r_{12}} \frac{kq_1q_2}{r^2} \cdot dx$$

$$W = -Kq_1q_2 \int_{\infty}^{r_{12}} \frac{1}{r^2} \cdot dx$$

$$W = -Kq_1q_2 \left[ -\frac{1}{r} \right]_{\infty}^{r_{12}}$$

$$W = Kq_1q_2 \left[ \frac{1}{r_{12}} \right]$$

$$W = U = \frac{Kq_1q_2}{r_{12}}$$

(b) Let us consider a system of two charges  $q_1$  and  $q_2$  located at a distance  $r_1$  and  $r_2$  from the origin. Let these charges be placed in an external field of magnitude  $E$ .

Let the work done in bringing the charge  $q_1$  from infinity to  $r_1$  be given as  $q_1V(r_1)$  and the work done in bringing the charge  $q_2$  from infinity to  $r_2$  against the external field can be given as  $q_2V(r_2)$ .

We note that, in the latter case, the work required to be done on  $q_2$  will include the field due to the charge  $q_1$  along with the electric field  $E$ , which can be given as,

$$= \frac{Kq_1q_2}{r_{12}}$$

The potential energy of the point  $q$  at a distance  $r$  from the origin in an external electric field is given as  $qV(r)$ .

Where  $V(r)$  is the external potential at that point.

Here,  $r_{12}$  is the distance between  $q_1$  and  $q_2$ . we can add these two to get the total work done in bringing  $q_2$  from infinity to  $r_2$

$$= q_2V(r_2) + \frac{Kq_1q_2}{r_{12}}$$

Thus, the total work done required to bring both the charges from infinity to the present configuration or the total potential energy of the system can be given as

$$= q_1V(r_1) + q_2V(r_2) + \frac{Kq_1q_2}{r_{12}}$$

### Question 29

What is a solar cell? Draw its V-I characteristics. Explain the three processes involved in its working.

**OR**

Draw the circuit diagram of a full wave rectifier. Explain its working showing its input and output waveforms.

**SOLUTION:**

- It is a semiconductor device used to convert photons of solar light into electricity.

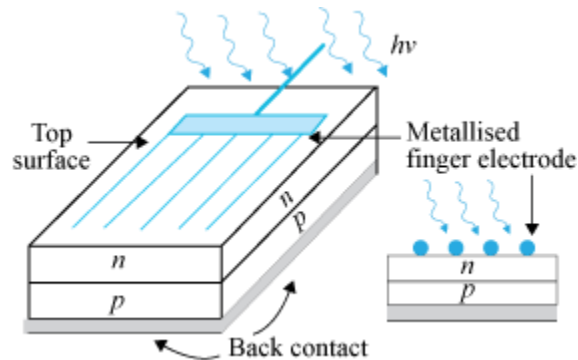

It generates emf when solar radiation fall on the  $p$ - $n$  junction. A  $p$ -type silicon wafer of about  $300\ \mu\text{m}$  is taken over which a thin layer of  $n$ -type silicon is grown on one side by diffusion process.

The generation of emf by a solar cell, when light falls on, it is due to the following three basic processes: **generation, separation and collection**

- (i) generation of e-h pairs due to light (with  $h\nu > E_g$ ) close to the junction
- (ii) separation of electrons and holes due to electric field of the depletion region. Electrons are swept to n-side and holes to p-side
- (iii) the electrons reaching the n-side are collected by the front contact and holes reaching p-side are collected by the back contact. Thus p-side becomes positive and n-side becomes negative giving rise to photo-voltage.

#### **V-I characteristic of a solar cell:**

The  $V$ - $I$  characteristic of a solar cell as follows:

- $I_{sc}$  is the short-circuit current when the load resistance  $R_L$  is zero.
- $V_{oc}$  is the open-circuit voltage when  $R_L$  is infinity.

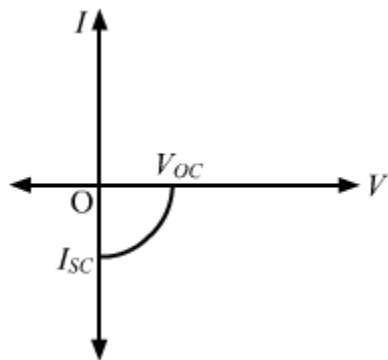

**OR**

The circuit diagram and the associated waveforms are shown below:

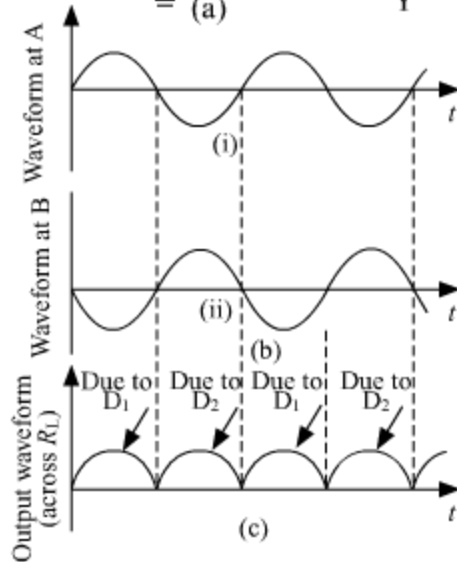
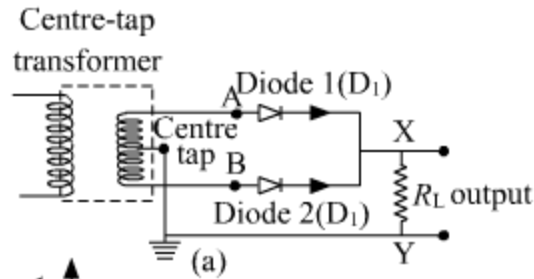

- (a) Full wave rectifier circuit
- (b) Input wave forms given to the diode  $D_1$  at A and to the diode  $D_2$  at B
- (c) Output wave form across the load  $R_L$  connected in the full-wave rectifier circuit

A Full Wave Rectifier is a circuit, which converts an ac voltage into a pulsating dc voltage using both half cycles of the applied ac voltage. It uses two diodes of which one conducts during one half cycle while the other conducts during the other half cycle of the applied ac voltage.

During the positive half cycle of the input voltage, diode  $D_1$  becomes forward biased and  $D_2$  becomes reverse biased. Hence  $D_1$  conducts and  $D_2$  remains OFF. The load current flows through  $D_1$  and the voltage drop across  $R_L$  will be equal to the input voltage.

During the negative half cycle of the input voltage, diode  $D_1$  becomes reverse biased and  $D_2$  becomes forward biased. Hence  $D_1$  remains OFF and  $D_2$  conducts. The load current flows through  $D_2$  and the voltage drop across  $R_L$  will be equal to the input voltage.

### Question 30

- (a) Define internal resistance of a cell.
- (b) A cell of emf  $E$  and internal resistance  $r$  is connected across a variable resistor  $R$ .

Plot the shape of graphs showing variation of terminal voltage  $V$  with (i)  $R$  and (ii) circuit current  $I$ .

**Solution:**

(a) Internal Resistance is the resistance which is present within the battery that resists the current flow when connected to a circuit.

(b) Terminal Voltage  $V$  can be related to  $R$  by the following relation:

$$(i) \quad V = \frac{ER}{R+r}$$
$$\Rightarrow V = \frac{E}{1 + \frac{r}{R}}$$

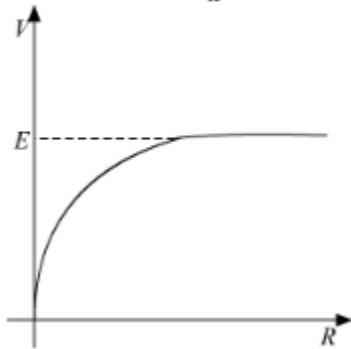

(ii) Terminal Voltage  $V$  can be related to  $I$  by the following relation:

$$V = E - IR$$

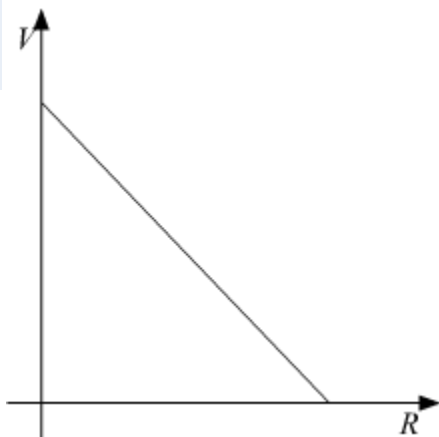

**Question 31**

Calculate the de-Broglie wavelength associated with the electron revolving in the first excited state of hydrogen atom. The ground state energy of the hydrogen atom is  $-13.6$  eV.

### Solution:

de-Broglie wavelength  $\lambda = \frac{h}{mv} = \frac{h}{p}$ , where  $p$  is momentum of electron

Kinetic energy (KE) and momentum ( $p$ ) are related by,  $\text{KE} = \frac{p^2}{2m}$  ( $m = \text{mass}$ )

$$\Rightarrow p = \sqrt{2m(\text{KE})}$$

$$\Rightarrow \lambda = \frac{h}{\sqrt{2m(\text{KE})}}$$

According to Bohr's model, **Kinetic Energy of  $e^-$**  = |Total Energy of  $e^-$ | =  $\left| -\frac{13.6 \times Z^2}{n^2} \right| \text{eV}$   
for Hydrogen  $Z = 1$  and first excited state implies  $n = 2$

$$\begin{aligned} \text{KE} &= \frac{13.6 \times 1^2}{2^2} = 3.4 \text{ eV} \\ &= 3.4 \times 1.6 \times 10^{-19} \text{ J} \\ &= 5.44 \times 10^{-19} \text{ J} \end{aligned}$$

putting the values in formula for wavelength we get,

$$\lambda = \frac{h}{\sqrt{2m(\text{KE})}} = \frac{6.63 \times 10^{-34}}{\sqrt{2 \times 9.1 \times 10^{-31} \times 5.44 \times 10^{-19}}} = 6.66 \times 10^{-10} \text{ m} = 6.66 \text{ \AA}$$

### Question 32

When a conducting loop of resistance  $10 \Omega$  and area  $10 \text{ cm}^2$  is removed from an external magnetic field acting normally, the variation of induced current- $i$  in the loop with time  $t$  is as shown in the figure.

Find the

- total charge passed through the loop.
- change in magnetic flux through the loop
- magnitude of the field applied

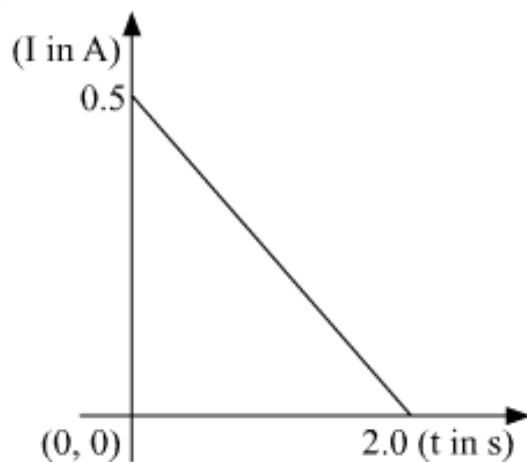

**Solution:**

$$I = \frac{dq}{dt} \Rightarrow dq = Idt$$

Hence area under the  $I$ - $t$  curve gives charge flown.

$$\text{Area of the } I\text{-}t \text{ curve (as given in the question)} = \frac{1}{2} \times 2 \times \frac{1}{2} = 0.5$$

Total charge passed through the loop = 0.5 C

Now we know

$$\Delta Q = \frac{\Delta \varphi}{R}$$

$$\Delta \varphi = \Delta Q \times R = \frac{1}{2} \times 10\Omega = 5 \text{ Wb}$$

Change in magnetic flux through the loop = 5 Wb

$$\Delta \varphi = B (\Delta A)$$

$$5 = B (0.001)$$

$$B = 5000 \text{ T}$$

The magnitude of the field applied = 5000 T

### Question 33

Draw the curve showing the variation of binding energy per nucleon with the mass number of nuclei. Using it explain the fusion of nuclei lying on ascending part and fission of nuclei lying on descending part of this curve.

**Solution:**

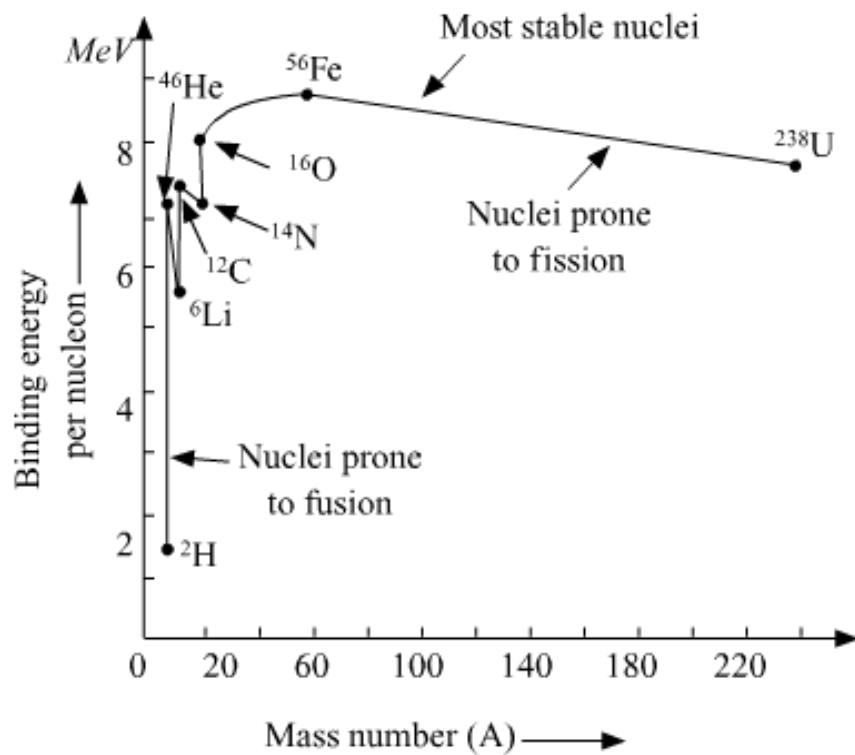

The above curve tells us that the binding energy per nucleon is smaller for heavier nuclei as well as for lighter nuclei than for the middle order nuclei (with mass number lying between 30 to 170). Meaning heavier nuclei are less stable thus they undergo fission and lighter nuclei undergo fusion in order to form the nucleus lying in the range of the mass number 30 to 170.

### Question 34

An optical instrument uses a lens of 100 D for the objective lens and 50 D for its eye piece. When the tube length is kept at 20 cm, the final image is formed at infinity.

- Identify the optical instrument.
- Calculate the magnification produced by the instrument.

**Solution:**



(a)

$$\text{Power of lens} = \frac{1}{\text{focal length}}$$

$$\text{So, focal length of objective lens} = \frac{1}{100} \text{ m} = 1 \text{ cm}$$

$$\text{focal length of eye piece} = \frac{1}{50} \text{ m} = 2 \text{ cm}$$

Since the objective has a smaller focal length than the eye piece, the instrument is a Compound Microscope.

(b)

Magnification produced when the image is formed at infinity is given by,  $m = \left(\frac{L}{f_o}\right) \left(\frac{D}{f_e}\right)$  where  $L$  is the tube length.

$$\text{So, } m = \frac{20 \times 25}{1 \times 2} = 250$$

### Question 35

(a) Write two important characteristics of equipotential surfaces.

(b) A thin circular ring of radius  $r$  is charged uniformly so that its linear charge density becomes  $\lambda$ . Derive an expression for the electric field at a point  $P$  at a distance  $x$  from it along the axis of the ring. Hence, prove that at large distances ( $x \gg r$ ), the ring behaves as a point charge.

**OR**

(a) State Gauss's law on electrostatics and drive an expression for the electric field due to a long straight thin uniformly charged wire (linear charge density  $\lambda$ ) at a point lying at a distance  $r$  from the wire.

(b) The magnitude of electric field (in  $\text{NC}^{-1}$ ) in a region varies with the distance  $r$ (in m) as

$$E = 10r + 5$$

By how much does the electric potential increase in moving from point at  $r = 1$  m to a point at  $r = 10$  m.

SOLUTION: (a) Two important characteristics of equipotential surfaces are:

- Potential remains at all the points on equipotential surface.
- No work is required to move a charge on an equipotential surface.

(b) Let consider a thin circular ring of radius  $r$  with charge density as  $\lambda$

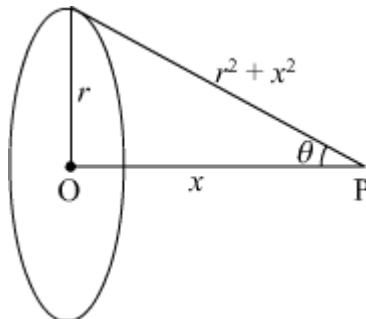

We need to find the electric field due to this charged ring at a point on the axis of the ring at a distance  $x$  from its centre.

Let us consider a small charge element ( $dx$ ) on the ring having small charge  $dq$

$$dq = \lambda dx$$

the electric field due to this charge element at the point P is given by

$$dE = \frac{1}{4\pi\epsilon_0} \frac{dq}{(r^2 + x^2)}$$

$$dE = \frac{1}{4\pi\epsilon_0} \frac{\lambda dx}{(r^2 + x^2)}$$

Electric field at the point P will have two components one in the vertical direction and the other one in the horizontal direction.

$dE \cos \theta$  along the horizontal direction.

$dE \sin \theta$  along the vertical direction.

The vertical components will cancel out the effect of each other due to the presence of the diametrically opposite element.

So the horizontal component of the electric field will survive at the point P.

$$\cos \theta = \frac{x}{\sqrt{r^2 + x^2}}$$

From the figure we have the value of

Now the integration of the horizontal component  $dE \cos \theta$  will be carried out.

$$dE \cos \theta = \frac{\lambda x dx}{4\pi\epsilon_0 (r^2 + x^2)^{3/2}}$$

Since the value of  $dq = \lambda dx$

$$dE \cos \theta = \frac{x dq}{4\pi\epsilon_0 (r^2 + x^2)^{3/2}}$$

Now integrating the above equation and taking  $x$  and  $r$  quantities as constants we get

$$E_x = \int dE \cos \theta = \int \frac{x dq}{4\pi\epsilon_0(r^2+x^2)^{3/2}}$$

$$E_x = \int \frac{x dq}{4\pi\epsilon_0(r^2+x^2)^{3/2}} = \frac{xQ}{4\pi\epsilon_0(r^2+x^2)^{3/2}}$$

where Q is the total charge on the ring.

Here  $E_x$  is the value of the total electric field at the point P

Special case:

when  $x \gg r$ , the denominator of the above equation gets modified in the following way:

$$r^2 + x^2 \approx x^2$$

$$E_x = \frac{xQ}{4\pi\epsilon_0(x^2)^{3/2}} = \frac{xQ}{4\pi\epsilon_0 x^3} = \frac{Q}{4\pi\epsilon_0 x^2}$$

So at large distances ( $x \gg r$ ), the ring behaves as a point charge.

**OR**

a) Gauss' Law states that the net electric flux through any closed surface is equal to  $1/\epsilon_0$  times the net electric charge within that closed surface.

$$\oint \vec{E} \cdot d\vec{s} = \frac{q_{\text{enclosed}}}{\epsilon_0}$$

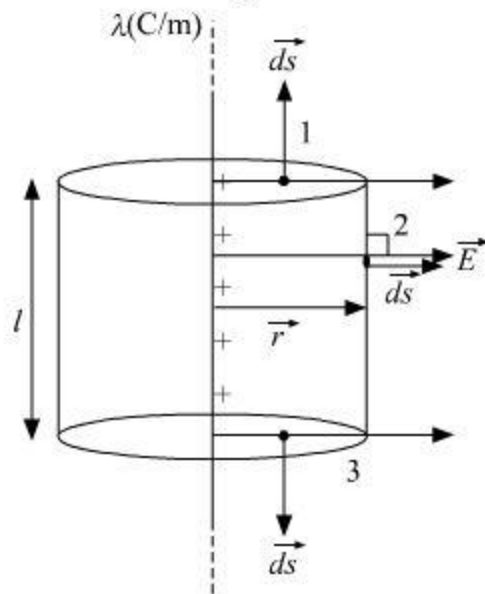

In the diagram we have taken a cylindrical gaussian surface of radius =  $r$  and length =  $l$ .

The net charge enclosed inside the gaussian surface  $q_{\text{enclosed}} = \lambda l$

By symmetry we can say that the Electric field will be in radially outward direction.

According to gauss' law,

$$\oint \vec{E} \cdot d\vec{s} = \frac{q_{\text{enclosed}}}{\epsilon_0}$$

$$\int_1 \vec{E} \cdot d\vec{s} + \int_2 \vec{E} \cdot d\vec{s} + \int_3 \vec{E} \cdot d\vec{s} = \frac{\lambda l}{\epsilon_0}$$

$\int_1 \vec{E} \cdot d\vec{s}$  &  $\int_3 \vec{E} \cdot d\vec{s}$  are zero , Since  $\vec{E}$  is perpendicular to  $d\vec{s}$

$$\int_2 \vec{E} \cdot d\vec{s} = \frac{\lambda l}{\epsilon_0}$$

at 2,  $\vec{E}$  and  $d\vec{s}$  are in the same direction, we can write

$$E \cdot 2\pi r l = \frac{\lambda l}{\epsilon_0}$$

$$E = \frac{\lambda}{2\pi\epsilon_0 r}$$

b) point A be given at  $r = 1$  m, point B be given at  $r = 10$  m

$V_A$  = potential at A

$V_B$  = potential at B

The relation between the electric field and potential difference is given by the relation,

$$\begin{aligned}V_B - V_A &= - \int_A^B \vec{E} \cdot d\vec{r} \\V_B - V_A &= - \int_1^{10} (10r + 5) \cdot dr \\&= - \left[ \frac{10r^2}{2} + 5r \right]_1^{10} \\&= - \left[ \left( \frac{10(10)^2}{2} + 5 \times 10 \right) - \left( \frac{10(1)^2}{2} + 5 \times 1 \right) \right] \\&= - \left[ 550 - 10 \right] \\&= - 540 \text{ V}\end{aligned}$$

### Question 36

(a) Define the term 'focal length of a mirror'. With the help of a ray diagram, obtain the relation between its focal length and radius of curvature.

(b) Calculate the angle of emergence ( $e$ ) of the ray of light incident normally on the face AC of a glass prism ABC of refractive index  $\sqrt{3}$ . How will the angle of emergence change qualitatively, if the ray of light emerges from the prism into a liquid of refractive index 1.3 instead of air?

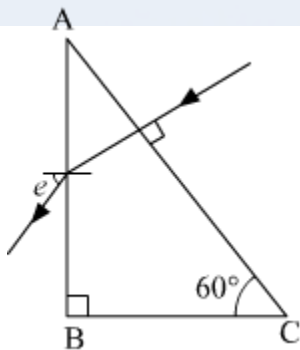

OR

(a) Define the term 'resolving power of a telescope'. How will the resolving power be effected with the increase in

- (i) Wavelength of light used.
- (ii) Diameter of the objective lens.

Justify your answers.

(b) A screen is placed 80 cm from an object. The image of the object on the screen is formed by a convex lens placed between them at two different locations separated by a distance 20 cm. determine the focal length of the lens.

**SOLUTION:**

(a) The distance between the centre of a lens or curved mirror and its focus.

The relationship between the focal length  $f$  and the radius of curvature  $R = 2f$ .

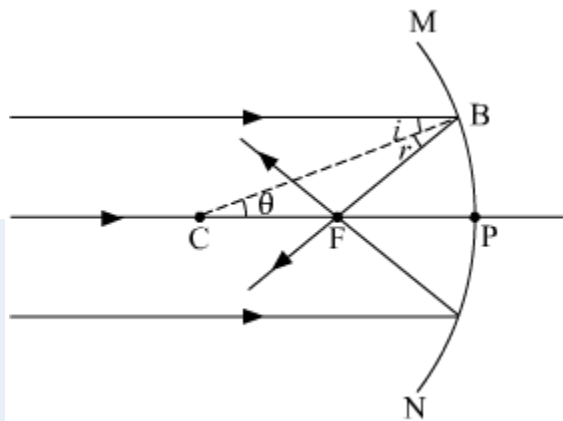

Consider a ray of light AB, parallel to the principal axis and incident on a spherical mirror at point B. The normal to the surface at point B is CB and  $CP = CB = R$  is the radius of curvature. The ray AB, after reflection from a mirror, will pass through F (concave mirror) or will appear to diverge from F (convex mirror) and obeys the law of reflection i.e.  $i = r$ .

From the geometry of the figure,

$$\angle BCP = \theta = i$$

$$\text{In } \triangle CBF, \theta = r$$

$$\therefore BF = FC \text{ (because } i = r \text{)}$$

If the aperture of the mirror is small, B lies close to P, and therefore  $BF = PF$

$$\text{Or } FC = FP = PF$$

$$\text{Or } PC = PF + FC = PF + PF$$

$$\text{Or } R = 2 PF = 2f$$

$$\text{Or } f = R/2$$

Similar relation holds for convex mirror also. In deriving this relation, we have assumed that the aperture of the mirror is small.

(b)

Snell's law says  $\mu_1 \sin(i) = \mu_2 \sin(r)$

$$\mu_{\text{Prism}} = \sqrt{3}$$

$$\mu_{\text{Prism}} \sin(30^\circ) = \sin(e)$$

$$\sqrt{3} \times \frac{1}{2} = \sin(e)$$

$$e = 60^\circ$$

Now when the external medium is changed to liquid of  $\mu_L = 1.3$  then,

$$\mu_{\text{prism}} \sin(30^\circ) = \mu_L \sin(e)$$

$$\sqrt{3} \sin(30^\circ) = 1.3 \sin(e)$$

$$e = \sin^{-1} \left( \frac{\sqrt{3}}{2 \times 1.3} \right) = 41.83^\circ$$

Hence the angle of emergence reduces to  $41.83^\circ$  from  $60^\circ$ .

(a) The resolving power of an astronomical telescope is defined as the reciprocal of the smallest angular separation between two point objects whose images can just be resolved by the telescope.

$$R.P = \frac{1.22\lambda}{D}$$

With the increase in wavelength of light, the resolving power increases whereas with the increase in diameter of the lens, the resolving power decreases.

(b) We have ,

case 1)

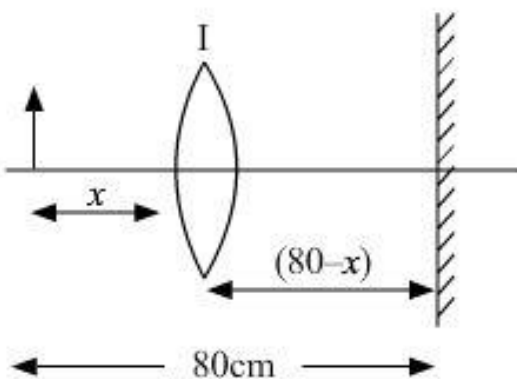

let object distance,  $u = x$

image distance,  $v = 80 - x$

focal length =  $f$

According to the lens formula:

$$\frac{1}{f} = \frac{1}{v} - \frac{1}{u}$$

$$\frac{1}{f} = \frac{1}{80-x} + \frac{1}{x} \quad \dots (1)$$

Similarly,

case 2)

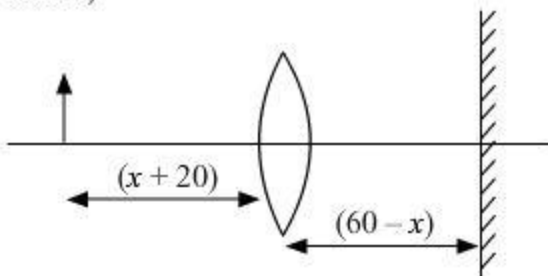

$$u = x + 20$$

$$v = 60 - x$$

$$\frac{1}{f} = \frac{1}{v} - \frac{1}{u} \quad \dots (2)$$

$$\frac{1}{f} = \frac{1}{60-x} + \frac{1}{20+x} \quad \dots (2)$$

On comparing equations 1 and 2, we get:

$$\frac{1}{f} = \frac{1}{80-x} + \frac{1}{x} = \frac{1}{60-x} + \frac{1}{20+x}$$

$$\frac{80}{x(80-x)} = \frac{80}{(60-x)(20+x)}$$

$$80x - x^2 = 1200 + 40x - x^2$$

$$40x = 1200$$

$$x = 30 \text{ cm}$$



Putting the value of  $x$  in equation (1)

$$\frac{1}{f} = \frac{1}{80-30} + \frac{1}{30}$$

$$\frac{1}{f} = \frac{1}{50} + \frac{1}{30}$$

$$\frac{1}{f} = \frac{8}{150}$$

$$f = 18.75 \text{ cm}$$

### Question 37

- (a) Show that an ideal inductor does not dissipate power in an ac circuit.  
(b) The variation of inductive reactance ( $X_L$ ) of an inductor with the frequency ( $f$ ) of the ac source of 100 V and variable frequency is shown in the fig.

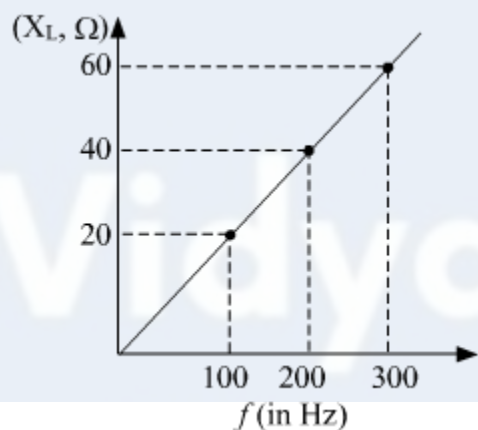

- (i) Calculate the self-inductance of the inductor.  
(ii) When this inductor is used in series with a capacitor of unknown value and resistor of  $10 \Omega$  at  $300 \text{ s}^{-1}$ , maximum power dissipation occurs in the circuit. Calculate the capacitance of the capacitor.

**OR**

- (a) A conductor of length ' $l$ ' is rotated about one of its ends at a constant angular speed ' $\omega$ ' in a plane perpendicular to a uniform magnetic field  $B$ . Plot graphs to show variations of the emf induced across the ends of the conductor with (i) angular speed  $\omega$  and (ii) length of the conductor  $l$ .
- (b) Two concentric circular loops of radius 1 cm and 20 cm are placed coaxially.  
(i) Find mutual inductance of the arrangement.  
(ii) If the current passed through the outer loop is changed at a rate of 5 A/ms, find the emf induced in the inner loop. Assume the magnetic field on the inner loop to be uniform.

SOLUTION:

(a)

$$\text{Power} = VI \cos \phi$$

For pure inductive circuit, the phase difference between current and voltage is  $\frac{\pi}{2}$ .

$$\therefore \phi = \frac{\pi}{2}, \cos \phi = 0$$

Therefore, zero power is dissipated. This current is sometimes referred to as watt-less current.

(b)

(i)

We know that  $X_L = \omega L$  and  $\omega = 2\pi f$  where  $f$  is frequency in Hz.

$$\text{So, } L = \frac{X_L}{2\pi f} = \frac{20}{2\pi(100)} = \frac{40}{2\pi(200)} = \frac{60}{2\pi(300)} = 31.84 \times 10^{-3} \approx 32 \text{ mH}$$

(ii)

we know that power dissipation is maximum when  $X_L = X_C$

$$\text{or } \omega L = \frac{1}{\omega C} \text{ or } C = \frac{1}{\omega^2 L}$$

$$\Rightarrow C = \frac{1}{4\pi^2 f^2 L} = \frac{1}{4 \times 3.14 \times 3.14 \times 300 \times 300 \times 32 \times 10^{-3}} = 8.8 \mu\text{F}$$

OR

(a)

$$\text{Induced emf} = E = \frac{B\omega l^2}{2}$$

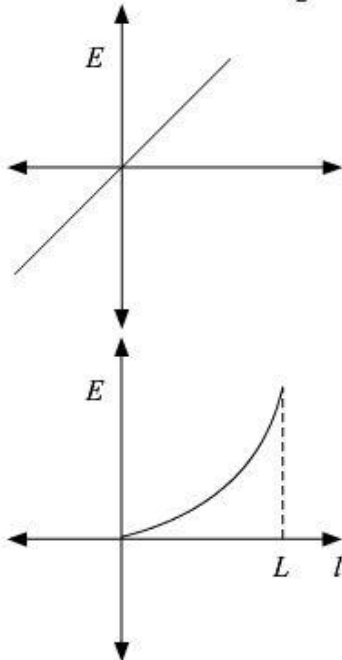

(b)

We know  $\varphi = MI$

And magnetic field at the center of the bigger loop  $\vec{B} = \frac{\mu_0 I}{2R} = \frac{4\pi \times 10^{-7} I}{2 \times 20 \times 10^{-2}} = \pi \times 10^{-6} I$

Flux through the smaller loop

$$\varphi = BA_s = \frac{4\pi \times 10^{-5} I}{40} \times \pi (0.01)^2 = \pi^2 \times 10^{-10} \times I$$

$$M = \frac{\varphi}{I} = \pi^2 \times 10^{-10} = 9.86 \times 10^{-10} \text{ H}$$

Now emf induced

$$e = -\frac{d\varphi}{dt} = -9.86 \times 10^{-10} \times \frac{dI}{dt}$$

$$e = -9.86 \times 10^{-10} \times 5 = -4.93 \times 10^{-9} \text{ V}$$



# Vidya Champ