

Science Delhi (Set 1)

General Instructions:

Read the following instructions very carefully and strictly follow them:

(i) Question paper comprises **three** sections - **A, B** and **C**.

There are **30** questions in the question paper. All questions are compulsory.

(ii) **Section A** - question no. 1 to 14 - all questions or part thereof are of one mark each. These questions comprises multiple choice questions (MCQ), very short answer (VSA), and Assertion-Reason type questions. Answer to these questions should be given in **one word or one sentence**.

(iii) **Section B** - question no. 15 to 24 are short answer type questions, carrying 3 marks each. Answer to these questions should not exceed 50 to 60 words.

(iv) **Section C** - question no. 25 to 30 are long answer type questions, carrying 5 marks each. Answer to these questions should not exceed 80 to 90 words.

(v) Answer should be brief and to the point. Also the above mentioned word limit be adhered to as far as possible.

(vi) There is no overall choice in the question paper. However, an internal choice has been provided in some questions in each Section. Only one of the choices in such questions have to be attempted.

(vii) In addition to this, separate instructions are given with each section and question, wherever necessary.

Science Delhi (Set 1)

Question 1

Name a cyclic unsaturated carbon compound.

Solution:

An example of a cyclic unsaturated compound is Cyclobutene.

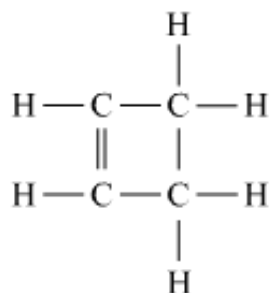

Cyclobutene

Question 2

The change in magnetic field lines in a coil is the cause of induced electric current in it. Name the underlying phenomenon.

Solution:

The phenomenon is Electromagnetic Induction

Question 3

The growing size of the human population is a cause of concern for all people. The rate of birth and death in a given population will determine its size. Reproduction is the process by which organisms increase their population. The process of sexual maturation for reproduction is gradual and takes place while general body growth is still going on. Some degree of sexual maturation does not necessarily mean that the mind or body is ready for sexual acts or for having and bringing up children. Various contraceptive devices are being used by human beings to control the size of population.

- (a) List two common signs of sexual maturation in boys and girls.
- (b) What is the result of reckless female foeticide?
- (c) Which contraceptive method changes the hormonal balance of the body?
- (d) Write two factors that determine the size of a population.

Solution:

a) Two common signs for sexual maturation in boys and girls are as follows:

- 1. Broadening of shoulder and chest in boys and development of mammary gland or breast in girls.
- 2. Appearance of hairs on various body parts like pubic area, armpits and face.

- b) The number of females will become very low in comparison to the males. Hence, there will be a huge imbalance between male female ratio in the population.
- c) Chemical method of contraception e.g. Oral pills interferes with the hormonal balance of the body.
- d) Birth rate and death rate are factors that determine the size of a population.

Question 4

Human body is made up of five important components, of which water is the main component. Food as well as potable water are essential for every human being. The food is obtained from plants through agriculture. Pesticides are being used extensively for a high yield in the fields. These pesticides are absorbed by the plants from the soil along with water and minerals and from the water bodies these pesticides are taken up by the aquatic animals and plants. As these chemicals are not biodegradables, they get accumulated progressively at each trophic level. The maximum concentration of these chemicals gets accumulated in our bodies and greatly affects the health of our mind and body.

- (a) Why is the maximum concentration of pesticides found in human beings?
- (b) Give one method which could be applied to reduce our intake of pesticides through food to some extent.
- (c) Various steps in a food chain represent :
- (a) Food web
 - (b) Trophic level
 - (c) Ecosystem
 - (d) Biomagnification
- (d) With regard to various food chains operating in an ecosystem, man is a:
- (a) Consumer
 - (b) Producer
 - (c) Producer and consumer
 - (d) Producer and decomposer

Solution:

- a) Maximum concentration of pesticides is found in human beings because humans are at the top of the food chain and due to biomagnification, the concentration of Dichlorodiphenyltrichloroethane (DDT) increases as one goes up the trophic levels.
- b) Instead of synthetic pesticides, organic farming should be done and more biopesticides should be used.
- c) The various steps in a food chain represent the trophic level.

Hence, the correct answer is option B.

- d) Man is a consumer with respect to various food chains operating in an ecosystem.

Hence, the correct answer is option A.

Question 5

Calcium oxide reacts vigorously with water to produce slaked lime.

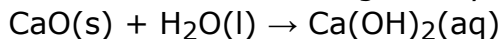

This reaction can be classified as:

- (A) Combination reaction
- (B) Exothermic reaction
- (C) Endothermic reaction
- (D) Oxidation reaction

Which of the following is a correct option?

- (a) (A) and (C)
- (b) (C) and (D)
- (c) (A), (C) and (D)
- (d) (A) and (B)

OR

When hydrogen sulphide gas is passed through a blue solution of copper sulphate, a black precipitate of copper sulphide is obtained and the sulphuric acid so formed remains in the solution. The reaction is an example of a:

- (a) Combination reaction
- (b) Displacement reaction
- (c) Decomposition reaction
- (d) Double displacement reaction

Solution:

When calcium oxide reacts with water it produces slaked lime and a huge amount of heat is released, this reaction can be classified as a combination reaction.

Hence, the correct answer is option (d).

OR

In the case of a double displacement reaction, two reactants exchange their ions and form new products.

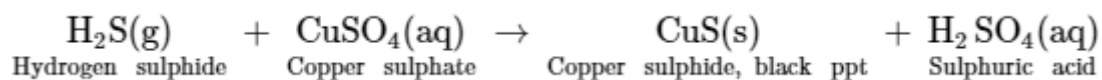

This reaction is an example of a double displacement reaction.

Hence, the correct answer is option (d).

Question 6

In a double displacement reaction such as the reaction between sodium sulphate solution and barium chloride solution:

- (A) exchange of atoms takes place
- (B) exchange of ions takes place
- (C) a precipitate is produced
- (D) an insoluble salt is produced

The correct option is:

- (a) (B) and (D)
- (b) (A) and (C)
- (c) only (B)
- (d) (B), (C) and (D)

Solution:

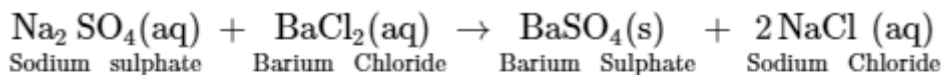

The white precipitate of BaSO_4 is formed by the reaction of SO_4^{2-} and Ba^{2+} .

Hence, the correct answer is option (d).

Question 7

Baking soda is a mixture of:

- (a) Sodium carbonate and acetic acid
- (b) Sodium carbonate and tartaric acid
- (c) Sodium hydrogen carbonate and tartaric acid
- (d) Sodium hydrogen carbonate and acetic acid

Solution:

Baking soda is a mixture of sodium hydrogen carbonate and tartaric acid.

Hence, the correct answer is option C.

Disclaimer: The question has an error. It should be baking powder instead of baking soda.

Question 8

The chemical formula for plaster of Paris is :

- (a) $\text{CaSO}_4 \cdot 2\text{H}_2\text{O}$
- (b) $\text{CaSO}_4 \cdot \text{H}_2\text{O}$
- (c) $\text{CaSO}_4 \cdot \frac{1}{2}\text{H}_2\text{O}$
- (d) $2\text{CaSO}_4 \cdot \text{H}_2\text{O}$

Solution:

The chemical formula of plaster of Paris is $\text{CaSO}_4 \cdot \frac{1}{2}\text{H}_2\text{O}$.

Hence, the correct answer is option C.

Question 9

The laws of reflection hold true for:

- (a) plane mirrors only

- (b) concave mirrors only
- (c) convex mirrors only
- (d) all reflecting surfaces

OR

When an object is kept within the focus of a concave mirror, an enlarged image is formed behind the mirror. This image is :

- (a) real
- (b) inverted
- (c) virtual and inverted
- (d) virtual and erect

Solution:

The laws of reflection holds true for all reflecting surfaces.

Thus, the correct answer is option (d).

OR

When an object is kept within the focus of a concave mirror, an enlarged image is formed behind the mirror. This image is virtual and erect.

Thus, the correct answer is option (d).

Question 10

At the time of short circuit, the electric current in the circuit :

- (a) vary continuously
- (b) does not change.
- (c) reduces substantially
- (d) increases heavily

OR

Two bulbs of 100 W and 40 W are connected in series. The current through the 100 W bulb is 1A. The current through the 40W bulb will be:

- (a) 0.4 A
- (b) 0.6 A
- (c) 0.8 A
- (d) 1 A

Solution:

At the time of short circuit the electric current in the circuit increases heavily.

Hence, the correct answer is option (d).

OR

In series connection, the current through each device remain same. Therefore, the current through the 40 W bulb will also be 1 A.

Hence, the correct answer is option (d).

Question 11

Which one of the following is responsible for the sustenance of underground water?

- (a) Loss of vegetation cover
- (b) Diversion for high water demanding crops
- (c) Pollution from urban wastes
- (d) Afforestation

Solution:

Afforestation prevents the water from immediately rushing into the rivers. Due to this, water can seep in the ground and replenish the groundwater.

Hence, the correct answer is option D.

Question 12

Incomplete combustion of coal and petroleum :

- (A) increases air pollution.
- (B) increases efficiency of machines.
- (C) reduces global warming.
- (D) produce poisonous gases.

The correct option is:

- (a) (A) and (B)
- (b) (A) and (D)
- (c) (B) and (C)
- (d) (C) and (D)

Solution:

Incomplete combustion of coal and petroleum increases air pollution and produce poisonous gases.

Hence, the correct answer is option (b).

Question 13

Two statements are given - one labelled Assertion (A) and the other labelled Reason (R).

Assertion (A): Esterification is a process in which a sweet smelling substance is produced.

Reason (R) : When esters react with sodium hydroxide an alcohol and sodium salt of carboxylic acid are obtained.

Select the correct answer to these questions from the codes (a), (b), (c) and (d) as given below.

- (a) Both A and R are true and R is the correct explanation of the Assertion.
- (b) Both A and R are true but R is not the correct explanation of the Assertion.
- (c) A is true but R is false.
- (d) A is false but R is true.

Solution:

Esterification is a process in which ethanoic acid reacts with absolute ethanol in the presence of an acid catalyst to give sweet-smelling substance called esters.

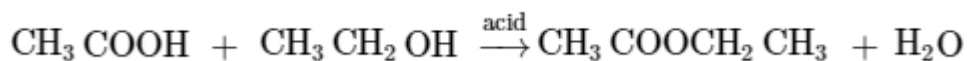

In this question, both the assertion and reason are correct but, the reason is not the correct explanation of the assertion.

Hence, the correct answer is option (b).

Question 14

Two statements are given - one labelled Assertion (A) and the other labelled Reason (R).

Assertion (A) : In the process of nuclear fission, the amount of nuclear energy generated by the fission of an atom of uranium is so tremendous that it produces 10 million times the energy produced by the combustion of an atom of carbon from coal.

Reason (R) : The nucleus of a heavy atom such as uranium, when bombarded with low energy neutrons, splits apart into lighter nuclei. The mass difference between the original nucleus and the product nuclei gets converted to tremendous energy.

Select the correct answer to these questions from the codes (a), (b), (c) and (d) as given below.

- (a) Both A and R are true and R is the correct explanation of the Assertion.
- (b) Both A and R true but R is not the correct explanation of the Assertion.
- (c) A is true but R is false.
- (d) A is false but R is true.

Solution:

When uranium-235 atoms are bombarded with slow-moving neutrons, the heavy uranium nucleus breaks up to produce two medium-weight atoms, barium-139 and krypton-94, with the emission of 3 neutrons.

The neutrons produced in a fission process cause further fission of the heavy nuclei leading to a self-sustaining chain reaction. When all the neutrons produced during the fission of uranium are allowed to cause further fission, then a large amount of energy is produced in a very short time that it cannot be controlled and this leads to an explosion called atom bomb. The energy thus generated by the fission of Uranium atom is 10 Million times the energy produced by the combustion of an atom of Carbon from Coal.

So, both Assertion and Reason is correct and Reason is the correct explanation of Assertion

Hence, the correct answer is option A.

Question 15

1 g of copper powder was taken in a China dish and heated. What change takes place on heating? When hydrogen gas is passed over this heated substance, a visible change is seen in it. Give the chemical equations of reactions, the name and the color of the products formed in each case.

Solution:

(i) How is 5% solution of KMnO_4 prepared?

(ii) State the role of alkaline potassium permanganate in this reaction. What happens on adding it in excess?

(iii) Write chemical equation of this reaction.

Solution:

(i) 5 g potassium permanganate is dissolved in 100 ml of water for preparing 5 % solution of KMnO_4 .

(ii) Alkaline potassium permanganate is adding oxygen to alcohol and converting that to an acid. Hence, it is acting as an oxidising agent. When KMnO_4 is added, initially colour disappears because coloured permanganate ions of potassium permanganate are consumed to oxidise ethanol. When an excess of KMnO_4 is added, colour does not change because there is no more alcohol left for the reaction.

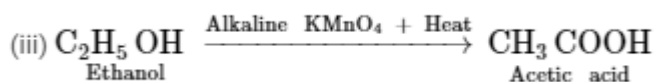

Question 18

A squirrel is in a scary situation. Its body has to prepare for either fighting or running away. State the immediate changes that take place in its body so that the squirrel is able to either fight or run?

OR

Why is chemical communication better than electrical impulses as a means of communication between cells in a multi-cellular organism?

Solution:

Adrenaline hormone will be secreted in the body as the squirrel is in a scary situation. This will result in following immediate changes:

- Speeding up of heartbeat
- Rise in blood pressure
- Release of more glucose in the blood

OR

Chemical communication is better than electrical impulses as a means of communication in a multi-cellular organism because of following reason:

Chemical communication is mediated through hormones which can diffuse to different regions of the body, thereby, allowing cells to communicate even without physically interacting with each other. Moreover, this type of communication can be maintained at a steady rate and is easy to regulate.

Question 19

Define the term pollination. Differentiate between self pollination and cross pollination. What is the significance of pollination?

Solution:

The process of transfer of pollen from an anther to the stigma is called pollination.

Self-pollination: It is the transfer of pollen from the anther to the stigma in the same flower or pollen is transferred from the anther of one flower to the stigma of another flower on the same plant.

Cross-pollination: It is the transfer of pollen from an anther of a flower to the stigma of a flower on another plant.

Significance of pollination:

Pollination is essential for the process of fertilization. Fertilization thereby results in the formation of fruits and seeds. Without pollination, there wouldn't be any fruit and seed formation.

Question 20

What are homologous structures? Give an example. Is it necessary that homologous structures always have a common ancestor. Justify your answer.

Solution:

Homologous organs: These are organs that are similar in origin, but perform different functions. For example, the forelimbs of humans and the wings of birds perform different functions, but their skeletal structures are similar.

Yes, homology indicates common ancestry. Homologous organs follow the same basic plan of organisation during their development but in the adult condition, these organs are modified to perform different functions as an adaptation to different environments.

Question 21

Why is Tyndall effect shown by colloidal particles? State four instances of observing the Tyndall effect.

OR

Differentiate between a glass slab and a glass prism. What happens when a narrow beam of (i) a monochromatic light, and (ii) white light passes through (a) glass slab and (b) glass prism?

Solution:

Tyndall Effect : It is the effect under which a ray of light scatters in all direction as soon as it encounters a colloidal or suspension particle. It is shown by colloidal particles because the colloidal particles size are roughly equal to the wavelength of the light.

Four instances of observing tyndall effect:

1. It can be observed in fog.
2. It can be observed when light passes through the canopy in forest.
3. It is the reason of blue colour of sky.
4. It can be observed when light passes through the milk.

OR

Glass slab: It is rectangular in shape and made up of glass. In glass slab, the direction of incident ray and emergent ray of light are parallel to each other.

Glass Prism: It has two triangular sides, two inclined rectangular sides and one rectangular base. In glass prism, the direction of incident ray and emergent ray of light are not parallel to each other.

When a narrow beam of monochromatic light passes through:

- Glass slab: It is deviated from the actual path but the direction of incident ray and emergent ray of light are parallel to each other.
- Glass prism: It is deviated from the actual path but the direction of incident ray and emergent ray of light are not parallel to each other.

When a narrow beam of white light passes through:

- Glass slab: The splitting of white light into its constituent colour does not occur. And the direction of incident ray and emergent ray of light are parallel to each other.
- Glass prism: The splitting of white light into its constituent seven colours occurs. And the direction of incident ray and emergent ray of light are not parallel to each other.

Question 22

Draw a labelled diagram to show (i) reddish appearance of the sun at the sunrise or the sunset and (ii) white appearance of the sun at noon when it is overhead.

Solution:

i) The reddish appearance of the sun at sunrise or sunset is due to the scattering of light by the molecules of air and other fine particles in the atmosphere that have the size smaller than the wavelength of visible light from the sun near the horizon. Light travels larger distances at the horizon in the earth's atmosphere before reaching our eyes and most of the blue light and shorter wavelengths are scattered away by the particles. So, only red light, being of higher wavelength reaches us which gives the reddish appearance of the sun at sunrise or sunset.

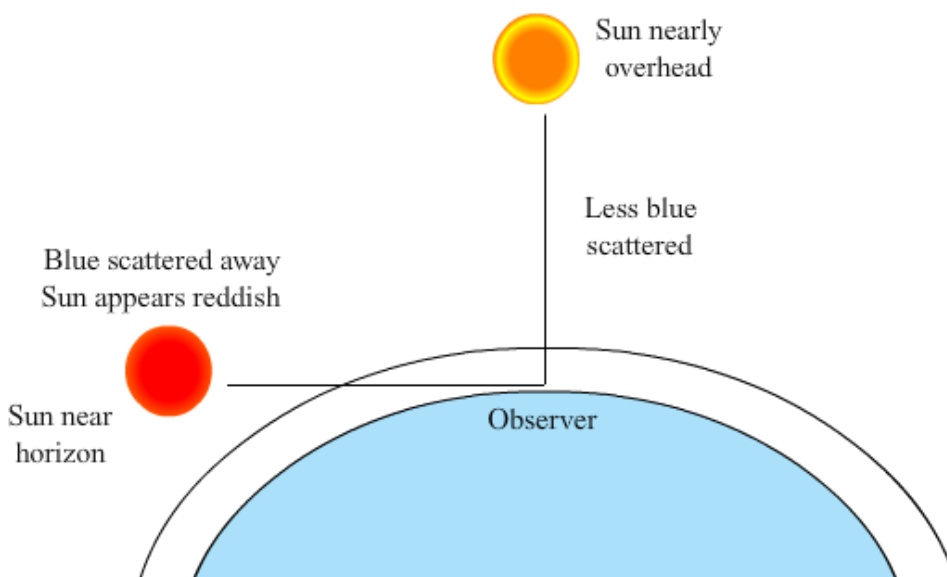

ii) At noon, the sun appears white, not red, as only a little of the blue and violet colors are scattered because light from the Sun overhead would travel a relatively shorter distance.

Question 23

A V-I graph for a nichrome wire is given below. What do you infer from this graph? Draw a labelled circuit diagram to obtain such a graph.

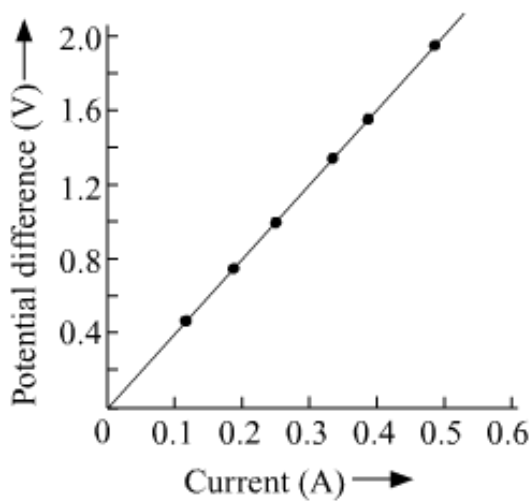

Solution:

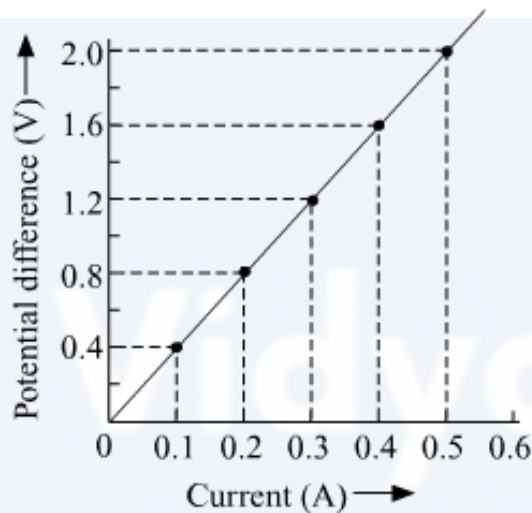

Graph between V & I is a straight line.

So we can conclude that Current flowing through the wire is directly proportional to the potential difference V across it.

Resistance of the wire can be calculated as

$$R = \frac{V}{I} = \frac{0.4}{0.1} = 4 \Omega$$

We can also conclude that nichrome wire has a constant value of the resistance as 4Ω .

nichrome wire follows ohm's law thus it behave as an ohmic conductor.

The circuit diagram corresponding to the above graph is as shown below.

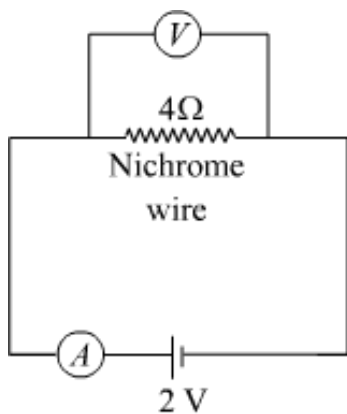

Question 24

- (a) Write the mathematical expression for Joule's law of heating,
 (b) Compute the heat generated while transferring 96000 coulomb of charge in two hours through a potential difference of 40 V.

Solution:

- (a) The mathematical expression of Joules Law of heating is:

$$H = I^2 R t$$

Here, H is heating effect, I is current flowing through the device and t is time taken.

(b)

Given:

Charge (Q) = 96000 C, Time (t) = 2h, Potential difference (V) = 40V

The heat generated,

$$H = V I t$$

$$= V \times \frac{Q}{t} \times t$$

$$= V \times Q$$

$$= 40 \times 96000$$

$$= 3840000 \text{ J}$$

Question 25

Carbon cannot reduce the oxides of sodium, magnesium and aluminium to their respective metals. Why? Where are these metals placed in the reactivity series? How are these metals obtained from their ores? Take an example to explain the process of extraction along with chemical equations.

Solution:

Oxides of sodium, magnesium and aluminium are very strong oxides as these metal are very reactive metals, but carbon is not a strong reducing agent and hence cannot reduce the reactive metal oxides to metals.

In the reactivity series, sodium, magnesium and aluminium are placed in the upper portion

which means these metals are very reactive in nature and carbon is less reactive.

$K > Na > Ca > Mg > Al > C > Zn > Fe$

$<Na < Ca < Mg < Al < Zn < Fe < Sn < Pb < H < Cu < Ag < Au$

Oxides of reactive metals are directly put for electrolytic reduction process to obtain the pure metal.

For the oxide of a reactive metal like aluminium oxide, as the metal is already in its oxide state so, it is directly put for the electrolytic reduction process. In this process, graphite electrodes are used as anode and cathode in the electrolytic chamber. The pure aluminium is attracted to the cathode, which is a lining of graphite. The oxygen is attracted to the anode, and bubbles through the solution.

Cathode reaction: at cathode reduction of aluminium takes place and thus aluminium is discharged at the cathode.

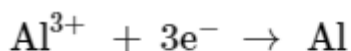

Anode reaction: at anode oxidation takes place and oxygen gas is evolved.

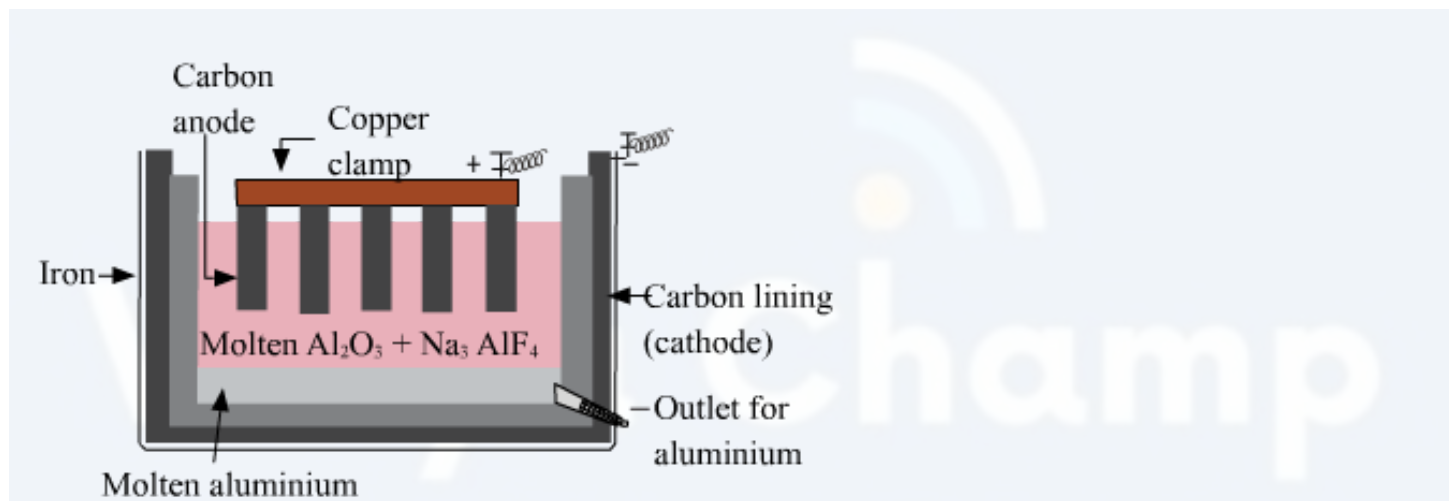
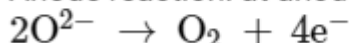

Electrolytic cell for the extraction of aluminium

Question 26

The position of certain elements in the Modern Periodic Table are shown below.

Group \ Period	1	2	3 to 12	13	14	15	16	17	18
1	G								H
2	A			I			B		C
3		D			E				F

Using the above table answer the following questions giving reasons in each case :

(1) Which element will form only covalent compounds?

(ii) Which element is a non-metal with valency 2?

- (iii) Which element is a metal with valency 2?
- (iv) Out of H, C and F which has largest atomic size?
- (v) To which family does H, C and F belong?

OR

Define atomic size. Give its unit of measurement. In the modern periodic table what trend is observed in the atomic radius in a group and a period and why is it so?

Solution:

- (i) Element E is Silicon. It will form covalent bond only. The outermost orbit of silicon has four electrons and it needs four more electrons to become stable.
- (ii) Non-metal with valency 2 is B, which is Oxygen. As Oxygen has a high electronegativity, due to which it has a higher tendency to attract electrons rather than donating them.
- (iii) Element D is a metal with valency 2. Element D is magnesium, due to its low electronegativity it has a very high tendency to donate electrons.
- (iv) Element F has the largest atomic size. According to the electronic configuration of element F which is argon, it occupies 3 energy shells compared to elements H and C which occupies one and two energy shells and due to this its atomic radius is the largest.
- (v) Elements H, C and F belong to Group number eighteen, which means according to their outer electronic configuration their octet is complete and thus these elements are stable. They have a very low tendency to react with other elements. Group eighteen elements belong to the noble gas family.

OR

Atomic size is the distance between the center of an atom i.e. from the nucleus to the outermost shell (valence shell) of that atom.

Atomic size is measured in Angstroms (Å), where 1 Angstrom = 10^{-10} meters.

In the modern periodic table, the atomic size of elements increases down the group and the atomic size decrease along the period from left to right.

Down the group, as the number of energy shells of the atoms keeps on increasing from top to bottom so, the atomic radius also increases.

Along the period, the atomic number of elements increases which leads to an increase in the number of protons inside the nucleus and thus, the effective nuclear charge increases. So, the atomic radius decreases along the period.

Question 27

- (a) Why is there a difference in the rate of breathing between aquatic organisms and terrestrial organisms? Explain.
- (b) Draw a diagram of human respiratory system and label - pharynx, trachea, lungs, diaphragm and alveolar sac on it.

OR

- (a) Name the organs that form the excretory system in human beings.
- (b) Describe in brief how urine is produced in human body.

Solution:

(a) The aquatic animals obtain oxygen in the dissolved form from the water. The amount of oxygen dissolved in water is much lower as compared to the amount of oxygen in the air (terrestrial environment) which necessitates high breathing rates in aquatic animals.

(b)

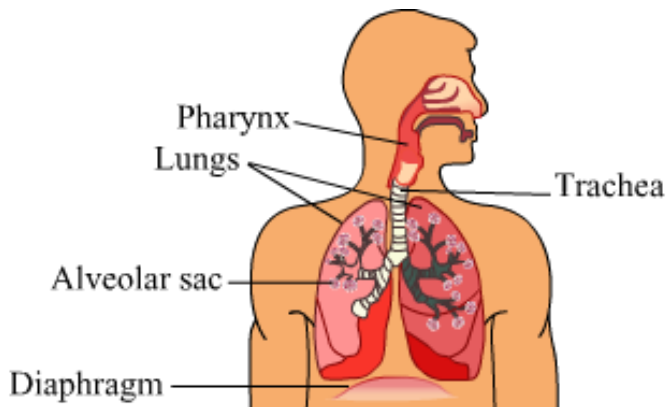

OR

(a) The human excretory system is composed of the following organs:

1. A pair of kidneys
2. A pair of ureters
3. A urinary bladder
4. A urethra

The typical structure of human excretory system can be represented as follows:

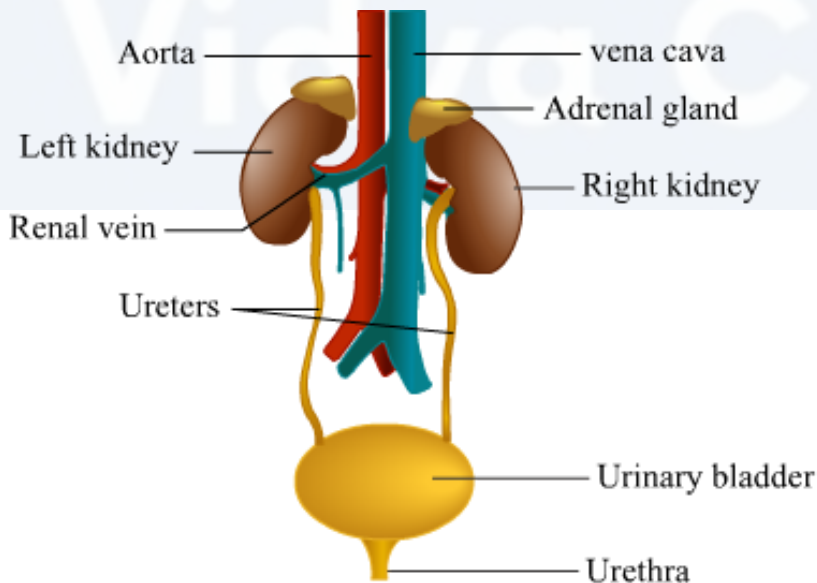

(b) Blood enters the kidneys through the renal artery, which branches into many capillaries associated with the glomerulus. Water and other solutes are transferred at the Bowman's capsule. In the proximal tubule, some substances such as amino acids, glucose and salts are selectively re-absorbed and unwanted molecules are removed. In the loop of Henle, water is re-absorbed. From here, the filtrate moves upwards into the distal tubule, and on to the collecting duct. This duct collects urine from many nephrons.

Question 28

- (a) What is the law of dominance of traits? Explain with an example.
 (b) Why are the traits acquired during the life-time-of-an individual not inherited? Explain.

Solution:

(a) **Law of Dominance:** According to this law, characters are controlled by discrete units called factors, which occur in pairs with one member of the pair dominating over the other in a dissimilar pair. This law explains the expression of only one of the parental characters in the F₁ generation and expression of both in the F₂ generation.

For example, a tall pea plant can be crossed with a dwarf pea plant in the following manner:

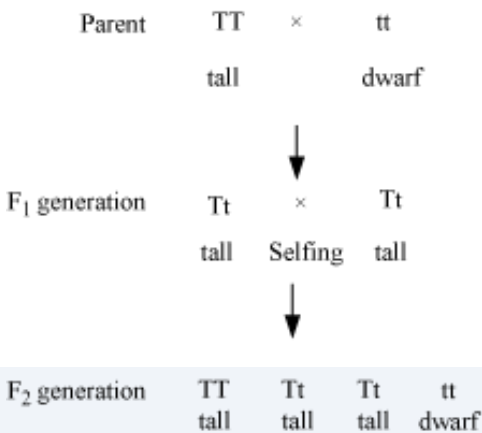

(b) Traits acquired during the lifetime of an individual are not inherited. This is because an acquired trait involves the change in somatic cells which are non-reproductive cells. These cells do not produce gametes and thus, these traits cannot be inherited.

Question 29

Draw a ray diagram in each of the following cases to show the formation of image, when the object is placed :

- (i) between optical centre and principal focus of a convex lens.
- (ii) anywhere in front of a concave lens.
- (iii) at 2F of a convex lens.

State the signs and values of magnifications in the above mentioned cases (i) and (ii).

OR

An object 4.0 cm in size, is placed 25.0 cm in front of a concave mirror of focal length 15.0 cm.

- (i) At what distance from the mirror should a screen be placed in order to obtain a sharp image?
- (ii) Find the size of the image.
- (iii) Draw a ray diagram to show the formation of image in this case.

Solution:

(i) When an object is placed between optical centre and principal focus of a convex lens

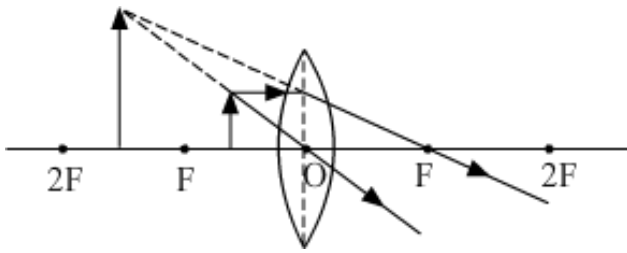

Since the image formed is virtual and erect so sign of magnification will be positive. Moreover, image formed is magnified therefore absolute value of magnification will be greater than one.

(ii) When an object is placed anywhere in front of a concave lens.

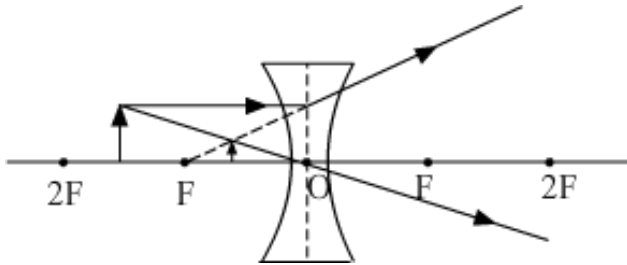

Since the image formed is virtual and erect so sign of magnification will be positive. Moreover, image formed is diminished therefore absolute value of magnification will be less than one.

(iii) When an object is placed at $2F$ of a convex lens.

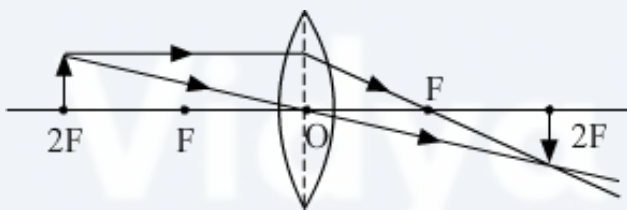

OR

Given:

Height of object (h_o) = 4 cm

Object distance (u) = -25 cm

Focal length (f) = -15 cm

(i)

Applying mirror formula and substituting the values,

$$\frac{1}{v} + \frac{1}{u} = \frac{1}{f}$$

$$\frac{1}{v} = \frac{1}{-15} - \frac{1}{-25}$$

$$\frac{1}{v} = \frac{-5+3}{75}$$

$$v = \frac{-75}{2} = -37.5 \text{ cm}$$

Negative sign indicates that the image is in front of the mirror.

Therefore, the screen must be placed in front of the mirror at a distance of 37.5 cm.

(ii)

Applying magnification formula and substituting the values,

$$m = \frac{-v}{u} = \frac{h_i}{h_o}$$

$$\frac{-\left(\frac{-75}{2}\right)}{-25} = \frac{h_i}{4}$$

$$h_i = \frac{-75}{2 \times 25} \times 4$$

$$h_i = -6 \text{ cm}$$

Negative sign indicates that the image is below the principal axis. Therefore, the size of the image is 6 cm.

(iii)

The ray diagram showing the formation of image in this case is,

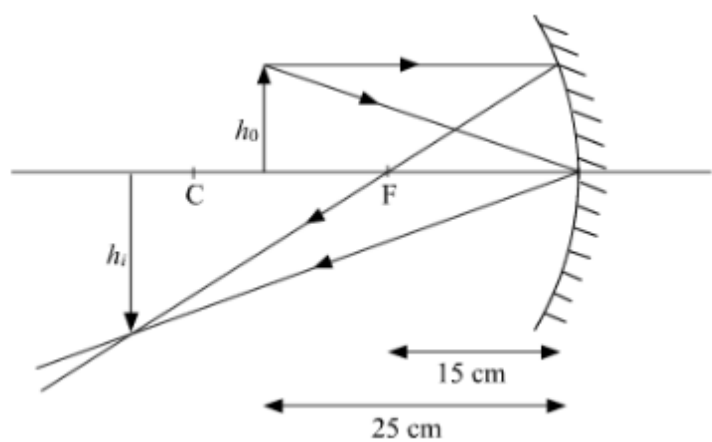

Question 30

- What is an electromagnet? List any two uses.
- Draw a labelled diagram to show how an electromagnet is made.
- State the purpose of soft iron core used in making an electromagnet.
- List two ways of increasing the strength of an electromagnet if the material of the electromagnet is fixed.

Solution:

a) The magnetic field produced due to the current flowing in a coil or a solenoid can be used to magnetize a material like soft iron temporarily. The insulated copper wire is wrapped on a soft iron piece. When current is passed through the coil using a battery and a key the iron piece behaves like a bar magnet as long as the current is being passed. Such a magnet is called an electromagnet.

Uses of Electromagnet :

- Magnets are used inside TVs, Sound speakers, and radios.
- Magnets are used inside a generator to transform mechanical energy to electrical energy

b) Diagram of Electromagnet:

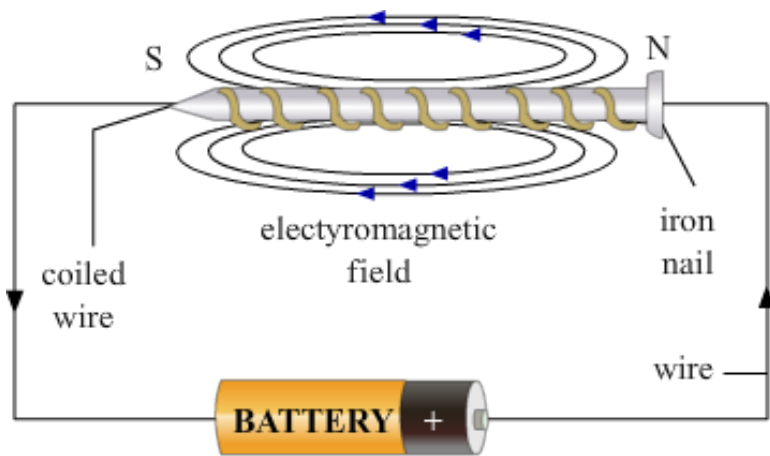

An electromagnetic field is formed when a current passes through the wire.

c) On placing a soft iron rod in a solenoid and passing a current, the magnetism of the solenoid is increased by a thousandfold. When the solenoid current is switched off, the magnetism is effectively switched off since the soft iron core has a low retentivity.

d) Two ways of increasing the strength of an electromagnet if the material of the electromagnet is fixed:

- i) By increasing the amount of current flowing in the solenoid, the strength of an electromagnet can be increased.
- ii) By increasing the number of turns in the solenoid, the strength of an electromagnet can be increased.

Vidya Champ