

Mathematics

(Chapter – 12) (Areas Related to Circles)

(Class – X)

Exercise 12.1

Question 1:

The radii of two circles are 19 cm and 9 cm respectively. Find the radius of the circle which has circumference equal to the sum of the circumferences of the two circles.

Answer 1:

Radius (r_1) of 1st circle = 19 cm

Radius (r_2) of 2nd circle = 9 cm

Let the radius of 3rd circle be r .

Circumference of 1st circle = $2\pi r_1 = 2\pi(19) = 38\pi$

Circumference of 2nd circle = $2\pi r_2 = 2\pi(9) = 18\pi$

Circumference of 3rd circle = $2\pi r$

Given that,

Circumference of 3rd circle = Circumference of 1st circle + Circumference of 2nd circle

$$2\pi r = 38\pi + 18\pi = 56\pi$$

$$r = \frac{56\pi}{2\pi} = 28$$

Therefore, the radius of the circle which has circumference equal to the sum of the circumferences of the given two circles is 28 cm.

Question 2:

The radii of two circles are 8 cm and 6 cm respectively. Find the radius of the circle having area equal to the sum of the areas of the two circles.

Answer 2:

Radius (r_1) of 1st circle = 8 cm

Radius (r_2) of 2nd circle = 6 cm

Let the radius of 3rd circle be r .

$$\text{Area of 1st circle} = \pi r_1^2 = \pi(8)^2 = 64\pi$$

$$\text{Area of 2nd circle} = \pi r_2^2 = \pi(6)^2 = 36\pi$$

Given that,

Area of 3rd circle = Area of 1st circle + Area of 2nd circle

$$\pi r^2 = \pi r_1^2 + \pi r_2^2$$

$$\pi r^2 = 64\pi + 36\pi$$

$$\pi r^2 = 100\pi$$

$$r^2 = 100$$

$$r = \pm 10$$

However, the radius cannot be negative. Therefore, the radius of the circle having area equal to the sum of the areas of the two circles is 10 cm.

Question 3:

Given figure depicts an archery target marked with its five scoring areas from the centre outwards as Gold, Red, Blue, Black and White. The diameter of the region representing Gold score is 21 cm and each of the other bands is 10.5 cm wide. Find the area of each of the five scoring regions [Use $\pi = \frac{22}{7}$].

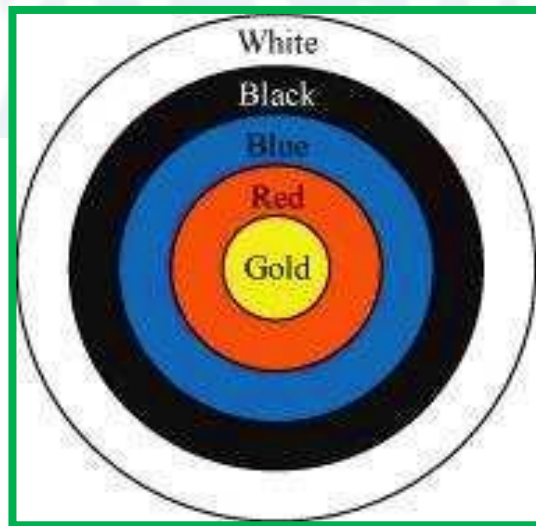

Answer 3:

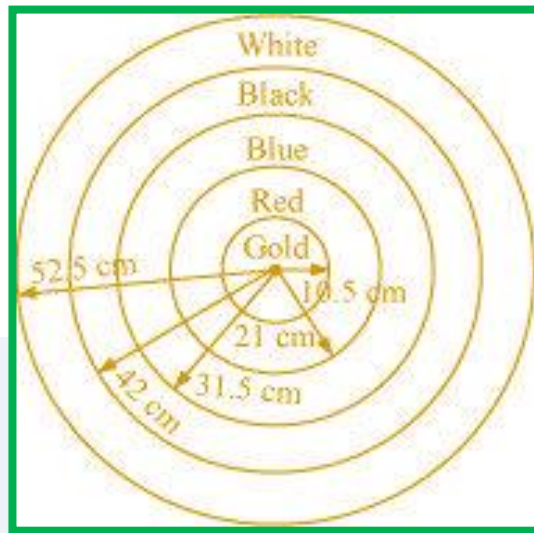

$$\text{Radius } (r_1) \text{ of gold region (i.e., 1}^{\text{st}} \text{ circle)} = \frac{21}{2} = 10.5 \text{ cm}$$

Given that each circle is 10.5 cm wider than the previous circle.

Therefore, radius (r_2) of 2nd circle = 10.5 + 10.5

21 cm

Radius (r_3) of 3rd circle = 21 + 10.5

= 31.5 cm

Radius (r_4) of 4th circle = 31.5 + 10.5

= 42 cm

Radius (r_5) of 5th circle = 42 + 10.5

= 52.5 cm

Area of gold region = Area of 1st circle = $\pi r_1^2 = \pi (10.5)^2 = 346.5 \text{ cm}^2$

Area of red region = Area of 2nd circle – Area of 1st circle

$$\begin{aligned}
&= \pi r_2^2 - \pi r_1^2 \\
&= \pi(21)^2 - \pi(10.5)^2 \\
&= 441\pi - 110.25\pi = 330.75\pi \\
&= 1039.5 \text{ cm}^2
\end{aligned}$$

Area of blue region = Area of 3rd circle – Area of 2nd circle

$$\begin{aligned}
&= \pi r_3^2 - \pi r_2^2 \\
&= \pi(31.5)^2 - \pi(21)^2 \\
&= 992.25\pi - 441\pi = 551.25\pi \\
&= 1732.5 \text{ cm}^2
\end{aligned}$$

Area of black region = Area of 4th circle – Area of 3rd circle

$$\begin{aligned}
&= \pi r_4^2 - \pi r_3^2 \\
&= \pi(42)^2 - \pi(31.5)^2 \\
&= 1764\pi - 992.25\pi \\
&= 771.75\pi = 2425.5 \text{ cm}^2
\end{aligned}$$

Area of white region = Area of 5th circle – Area of 4th circle

$$\begin{aligned}
&= \pi r_5^2 - \pi r_4^2 \\
&= \pi(52.5)^2 - \pi(42)^2 \\
&= 2756.25\pi - 1764\pi \\
&= 992.25\pi = 3118.5 \text{ cm}^2
\end{aligned}$$

Therefore, areas of gold, red, blue, black, and white regions are 346.5 cm², 1039.5 cm², 1732.5 cm², 2425.5 cm², and 3118.5 cm² respectively.

Question 4:

The wheels of a car are of diameter 80 cm each. How many complete revolutions does each wheel make in 10 minutes when the car is traveling at a speed of 66 km per hour? [Use $\pi = \frac{22}{7}$].

Answer 4:

Diameter of the wheel of the car = 80 cm

Radius (r) of the wheel of the car = 40 cm

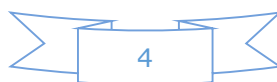

Circumference of wheel = $2\pi r$

$$= 2\pi (40) = 80\pi \text{ cm}$$

Speed of car = 66 km/hour

$$= \frac{66 \times 100000}{60} \text{ cm/min}$$

$$= 110000 \text{ cm/min}$$

Distance travelled by the car in 10 minutes

$$= 110000 \times 10 = 1100000 \text{ cm}$$

Let the number of revolutions of the wheel of the car be n .

$n \times$ Distance travelled in 1 revolution (i.e., circumference)

= Distance travelled in 10 minutes

$$n \times 80\pi = 1100000$$

$$n = \frac{1100000 \times 7}{80 \times 22}$$

$$= \frac{35000}{8} = 4375$$

Therefore, each wheel of the car will make 4375 revolutions.

Question 5:

Tick the correct answer in the following and justify your choice: If the perimeter and the area of a circle are numerically equal, then the radius of the circle is

(A) 2 units

(B) π units

(C) 4 units

(D) 7 units

Answer 5:

Let the radius of the circle be r .

Circumference of circle = $2\pi r$

Area of circle = πr^2

Given that, the circumference of the circle and the area of the circle are equal.

This implies $2\pi r = \pi r^2$

$$2 = r$$

Therefore, the radius of the circle is 2 units.

Hence, the correct answer is (A).



Mathematics

(Chapter 12) (Areas Related to Circles)

(Class - X)

Exercise 12.2

Question 1:

Find the area of a sector of a circle with radius 6 cm if angle of the sector is 60°
[Use $\pi = \frac{22}{7}$].

Answer 1:

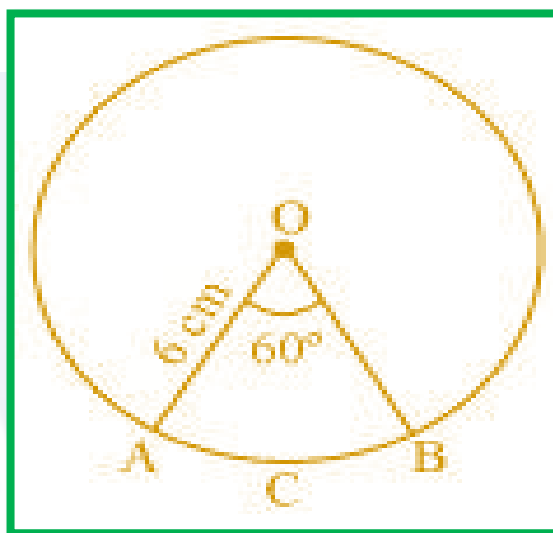

Let OACB be a sector of the circle making 60° angle at centre O of the circle.

$$\text{Area of sector of angle } \theta = \frac{\theta}{360^\circ} \times \pi r^2$$

$$\text{Area of sector OACB} = \frac{60^\circ}{360^\circ} \times \frac{22}{7} \times (6)^2$$

$$= \frac{1}{6} \times \frac{22}{7} \times 6 \times 6 = \frac{132}{7} \text{ cm}^2$$

Therefore, the area of the sector of the circle making 60° at the centre of the circle is $\frac{132}{7} \text{ cm}^2$.

Question 2:

Find the area of a quadrant of a circle whose circumference is 22 cm [Use $\pi = \frac{22}{7}$].

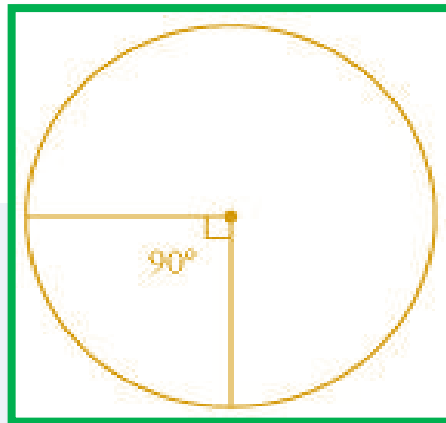
Answer 2:

Let the radius of the circle be r .

Circumference = 22 cm

$$2\pi r = 22$$

$$r = \frac{22}{2\pi} = \frac{11}{\pi}$$

Quadrant of circle will subtend 90° angle at the centre of the circle.

$$\text{Area of such quadrant of the circle} = \frac{90^\circ}{360^\circ} \times \pi \times r^2$$

$$= \frac{1}{4} \times \pi \times \left(\frac{11}{\pi}\right)^2$$

$$= \frac{121}{4\pi} = \frac{121 \times 7}{4 \times 22}$$

$$= \frac{77}{8} \text{ cm}^2$$

Question 3:

The length of the minute hand of a clock is 14 cm. Find the area swept by the minute hand in 5 minutes $\left[Use \pi = \frac{22}{7}\right]$.

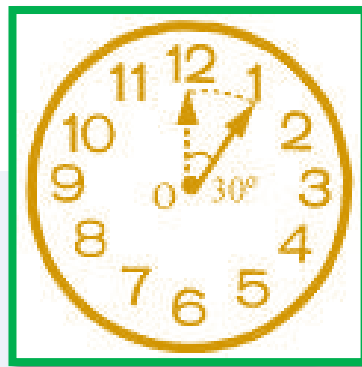
Answer 3:

We know that in 1 hour (i.e., 60 minutes), the minute hand rotates 360° .

In 5 minutes, minute hand will rotate = $\frac{360^\circ}{60} \times 5 = 30^\circ$

Therefore, the area swept by the minute hand in 5 minutes will be the area of a sector of 30° in a circle of 14 cm radius.

$$\text{Area of sector of angle } \theta = \frac{\theta}{360^\circ} \times \pi r^2$$

$$\text{Area of sector of } 30^\circ = \frac{30^\circ}{360^\circ} \times \frac{22}{7} \times 14 \times 14$$

$$= \frac{22}{12} \times 2 \times 14$$

$$= \frac{11 \times 14}{3}$$

$$= \frac{154}{3} \text{ cm}^2$$

Therefore, the area swept by the minute hand in 5 minutes is $154/3 \text{ cm}^2$.

Question 4:

A chord of a circle of radius 10 cm subtends a right angle at the centre. Find the area of the corresponding:

(i) Minor segment

(ii) Major sector

[Use $\pi = 3.14$]

Answer 4:

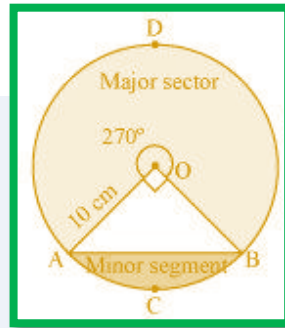

Let AB be the chord of the circle subtending 90° angle at centre O of the circle.

$$\begin{aligned} \text{(ii) Area of major sector OADB} &= \left(\frac{360^\circ - 90^\circ}{360^\circ} \right) \times \pi r^2 = \left(\frac{270^\circ}{360^\circ} \right) \pi r^2 \\ &= \frac{3}{4} \times 3.14 \times 10 \times 10 \end{aligned}$$

$$\begin{aligned} &= 235.5 \text{ cm}^2 \\ \text{Area of minor sector OACB} &= \frac{90^\circ}{360^\circ} \times \pi r^2 \\ &= \frac{1}{4} \times 3.14 \times 10 \times 10 \\ &= 78.5 \text{ cm}^2 \end{aligned}$$

$$\begin{aligned} \text{Area of } \triangle OAB &= \frac{1}{2} \times OA \times OB = \frac{1}{2} \times 10 \times 10 \\ &= 50 \text{ cm}^2 \end{aligned}$$

$$\begin{aligned} \text{(i) Area of minor segment ACB} &= \text{Area of minor sector OACB} - \text{Area of } \triangle OAB \\ &= 78.5 - 50 = 28.5 \text{ cm}^2 \end{aligned}$$

Question 5:

In a circle of radius 21 cm, an arc subtends an angle of 60° at the centre. Find:

- (i) The length of the arc
- (ii) Area of the sector formed by the arc
- (iii) Area of the segment formed by the corresponding chord

[Use $\pi = \frac{22}{7}$]

Answer 5:

Radius (r) of circle = 21 cm

Angle subtended by the given arc = 60°

- (i) Length of an arc of a sector of angle $\theta = \frac{\theta}{360^\circ} \times 2\pi r$

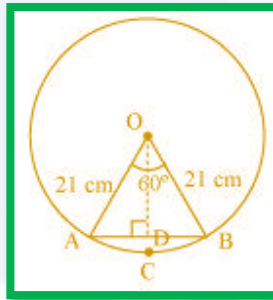

$$\text{Length of arc ACB} = \frac{60^\circ}{360^\circ} \times 2 \times \frac{22}{7} \times 21$$

$$= \frac{1}{6} \times 2 \times 22 \times 3$$

$$= 22 \text{ cm}$$

- (ii) Area of sector OACB = $\frac{60^\circ}{360^\circ} \times \pi r^2$

$$= \frac{1}{6} \times \frac{22}{7} \times 21 \times 21$$

$$= 231 \text{ cm}^2$$

In $\triangle OAB$,

$$\angle OAB = \angle OBA \quad (\text{As } OA = OB)$$

$$\angle OAB + \angle AOB + \angle OBA = 180^\circ$$

$$2\angle OAB + 60^\circ = 180^\circ$$

$$\angle OAB = 60^\circ$$

Therefore, ΔOAB is an equilateral triangle.

$$\begin{aligned}\text{Area of } \Delta OAB &= \frac{\sqrt{3}}{4} \times (\text{Side})^2 \\ &= \frac{\sqrt{3}}{4} \times (21)^2 = \frac{441\sqrt{3}}{4} \text{ cm}^2\end{aligned}$$

(iii) Area of segment ACB = Area of sector OACB – Area of ΔOAB

$$= \left(231 - \frac{441\sqrt{3}}{4} \right) \text{ cm}^2$$

Question 6:

A chord of a circle of radius 15 cm subtends an angle of 60° at the centre. Find the areas of the corresponding minor and major segments of the circle. [Use $\pi = 3.14$ and $\sqrt{3} = 1.73$]

Answer 6:

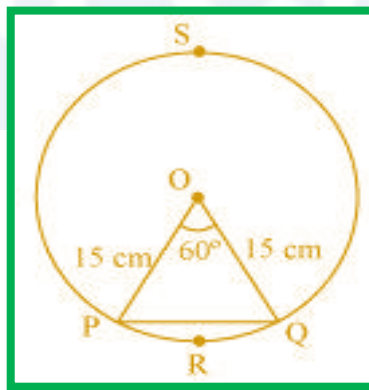

Radius (r) of circle = 15 cm

$$\text{Area of sector OPRQ} = \frac{60^\circ}{360^\circ} \times \pi r^2$$

$$= \frac{1}{6} \times 3.14 \times (15)^2$$

$$= 117.75 \text{ cm}^2$$

In ΔOPQ ,

$$\angle OPQ = \angle OQP \quad (\text{As } OP = OQ)$$

$$\angle OPQ + \angle OQP + \angle POQ = 180^\circ$$

$$2 \angle OPQ = 120^\circ$$

$$\angle OPQ = 60^\circ$$

ΔOPQ is an equilateral triangle.

$$\text{Area of } \Delta OPQ = \frac{\sqrt{3}}{4} \times (\text{side})^2$$

$$= \frac{\sqrt{3}}{4} \times (15)^2 = \frac{225\sqrt{3}}{4} \text{ cm}^2$$

$$= 56.25\sqrt{3}$$

$$= 97.3125 \text{ cm}^2$$

Area of segment PRQ = Area of sector OPRQ – Area of ΔOPQ

$$= 117.75 - 97.3125$$

$$= 20.4375 \text{ cm}^2$$

Area of major segment PSQ = Area of circle – Area of segment PRQ

$$= \pi(15)^2 - 20.4375$$

$$= 3.14 \times 225 - 20.4375$$

$$= 706.5 - 20.4375$$

$$= 686.0625 \text{ cm}^2$$

Question 7:

A chord of a circle of radius 12 cm subtends an angle of 120° at the centre. Find the area of the corresponding segment of the circle. [Use $\pi = 3.14$ and $\sqrt{3} = 1.73$]

Answer 7:

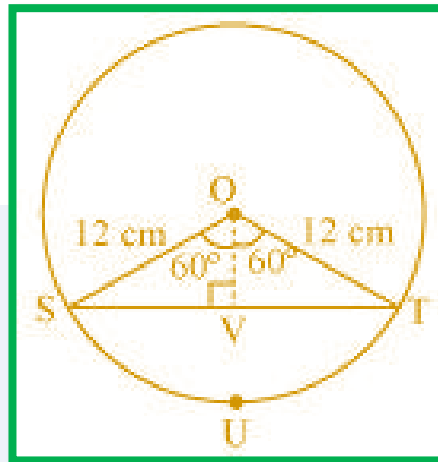

Let us draw a perpendicular OV on chord ST. It will bisect the chord ST.

$$SV = VT$$

In $\triangle OVS$,

$$\frac{OV}{OS} = \cos 60^\circ$$

$$\frac{OV}{12} = \frac{1}{2}$$

$$OV = 6 \text{ cm}$$

$$\frac{SV}{SO} = \sin 60^\circ = \frac{\sqrt{3}}{2}$$

$$\frac{SV}{12} = \frac{\sqrt{3}}{2}$$

$$SV = 6\sqrt{3} \text{ cm}$$

$$ST = 2SV = 2 \times 6\sqrt{3} = 12\sqrt{3} \text{ cm}$$

$$\text{Area of } \Delta OST = \frac{1}{2} \times ST \times OV$$

$$= \frac{1}{2} \times 12\sqrt{3} \times 6$$

$$= 36\sqrt{3} = 36 \times 1.73 = 62.28 \text{ cm}^2$$

$$\text{Area of sector OSUT} = \frac{120^\circ}{360^\circ} \times \pi(12)^2$$

$$= \frac{1}{3} \times 3.14 \times 144 = 150.72 \text{ cm}^2$$

Area of segment SUT = Area of sector OSUT – Area of ΔOST

$$= 150.72 - 62.28$$

$$= 88.44 \text{ cm}^2$$

Question 8:

A horse is tied to a peg at one corner of a square shaped grass field of side 15 m by means of a 5 m long rope (see the given figure). Find

(i) The area of that part of the field in which the horse can graze.

(ii) The increase in the grazing area of the rope were 10 m long instead of 5 m.

[Use $\pi = 3.14$]

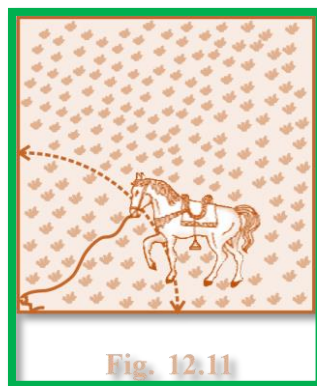

Answer 8:

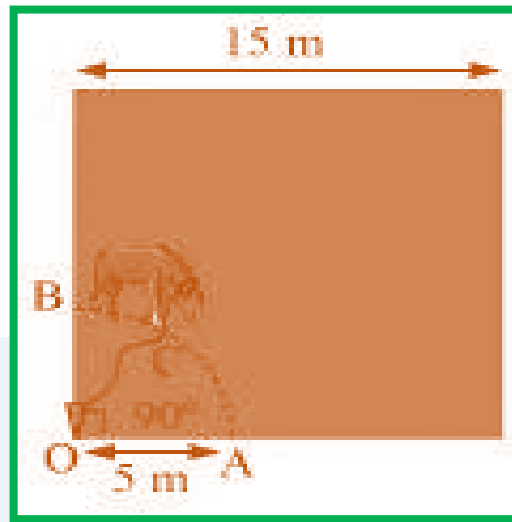

From the figure, it can be observed that the horse can graze a sector of 90° in a circle of 5 m radius.

(i) Area that can be grazed by horse = Area of sector OACB

$$\begin{aligned} &= \frac{90^\circ}{360^\circ} \pi r^2 \\ &= \frac{1}{4} \times 3.14 \times (5)^2 \\ &= 19.625 \text{ m}^2 \end{aligned}$$

Area that can be grazed by the horse when length of rope is 10 m long

$$\begin{aligned} &= \frac{90^\circ}{360^\circ} \times \pi \times (10)^2 \\ &= \frac{1}{4} \times 3.14 \times 100 \\ &= 78.5 \text{ m}^2 \end{aligned}$$

(ii) Increase in grazing area = $(78.5 - 19.625) \text{ m}^2$

$$= 58.875 \text{ m}^2$$

Question 9:

A brooch is made with silver wire in the form of a circle with diameter 35 mm. The wire is also used in making 5 diameters which divide the circle into 10 equal sectors as shown in figure. Find.

(i) The total length of the silver wire required.

(ii) The area of each sector of the brooch

$$\left[\text{Use } \pi = \frac{22}{7} \right]$$

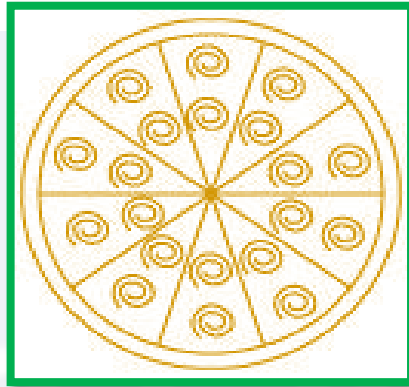

Answer 9:

Total length of wire required will be the length of 5 diameters and the circumference of the brooch.

$$\text{Radius of circle} = 35/2 \text{ mm}$$

$$\text{Circumference of brooch} = 2\pi r$$

$$= 2 \times \frac{22}{7} \times \left(\frac{35}{2} \right)$$

$$= 110 \text{ mm}$$

$$\text{(i) Length of wire required} = 110 + 5 \times 35$$

$$= 110 + 175 = 285 \text{ mm}$$

It can be observed from the figure that each of 10 sectors of the circle is subtending 36° at the centre of the circle.

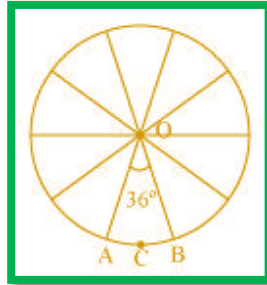

(ii) Therefore, area of each sector = $\frac{36^\circ}{360^\circ} \times \pi r^2$

$$= \frac{1}{10} \times \frac{22}{7} \times \left(\frac{35}{2}\right) \times \left(\frac{35}{2}\right)$$

$$= \frac{385}{4} \text{ mm}^2$$

Question 10:

An umbrella has 8 ribs which are equally spaced (see figure). Assuming umbrella to be a flat circle of radius 45 cm, find the area between the two consecutive ribs of the umbrella. [Use $\pi = \frac{22}{7}$]

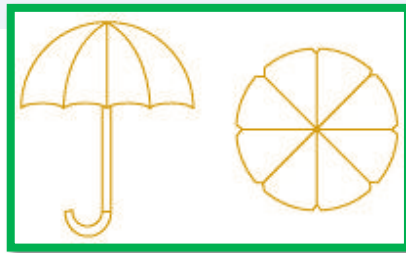

Answer 10:

There are 8 ribs in an umbrella. The area between two consecutive ribs is subtending

$$\frac{360^\circ}{8} = 45^\circ \text{ at the centre of the assumed flat circle.}$$

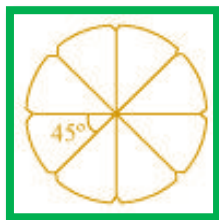

$$\begin{aligned} \text{Area between two consecutive ribs of circle} &= \frac{45^\circ}{360^\circ} \times \pi r^2 \\ &= \frac{1}{8} \times \frac{22}{7} \times (45)^2 \\ &= \frac{11}{28} \times 2025 = \frac{22275}{28} \text{ cm}^2 \end{aligned}$$

Question 11:

A car has two wipers which do not overlap. Each wiper has blade of length 25 cm sweeping through an angle of 115° . Find the total area cleaned at each sweep of the blades. [Use $\pi = \frac{22}{7}$]

Answer 11:

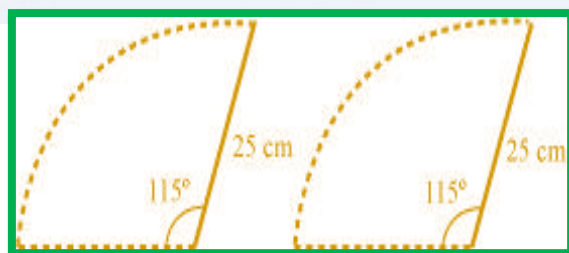

It can be observed from the figure that each blade of wiper will sweep an area of a sector of 115° in a circle of 25 cm radius.

$$\begin{aligned} \text{Area of such sector} &= \frac{115^\circ}{360^\circ} \times \pi \times (25)^2 \\ &= \frac{23}{72} \times \frac{22}{7} \times 25 \times 25 \\ &= \frac{158125}{252} \text{ cm}^2 \end{aligned}$$

$$\begin{aligned} \text{Area swept by 2 blades} &= 2 \times \frac{158125}{252} \\ &= \frac{158125}{126} \text{ cm}^2 \end{aligned}$$

Question 12:

To warn ships for underwater rocks, a lighthouse spreads a red coloured light over a sector of angle 80° to a distance of 16.5 km. Find the area of the sea over which the ships warned. [Use $\pi = 3.14$]

Answer 12:

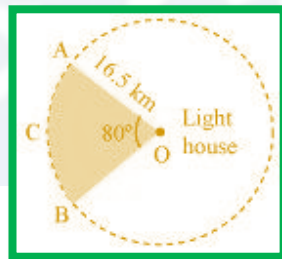

It can be observed from the figure that the lighthouse spreads light across a sector of 80° in a circle of 16.5 km radius.

$$\begin{aligned} \text{Area of sector OACB} &= \frac{80^\circ}{360^\circ} \times \pi r^2 \\ &= \frac{2}{9} \times 3.14 \times 16.5 \times 16.5 \\ &= 189.97 \text{ km}^2 \end{aligned}$$

Question 13:

A round table cover has six equal designs as shown in figure. If the radius of the cover is 28 cm, find the cost of making the designs at the rate of Rs.0.35 per cm^2 . [Use $\sqrt{3} = 1.7$]

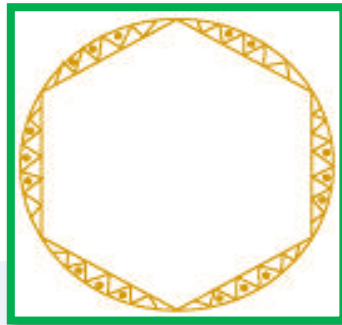

Answer 13:

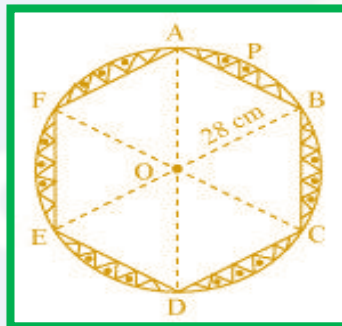

It can be observed that these designs are segments of the circle.

Consider segment APB. Chord AB is a side of the hexagon. Each chord will subtend

$$\frac{360^\circ}{6} = 60^\circ \text{ at the centre of the circle.}$$

In $\triangle OAB$,

$$\angle OAB = \angle OBA \quad (\text{As } OA = OB)$$

$$\angle AOB = 60^\circ$$

$$\angle OAB + \angle OBA + \angle AOB = 180^\circ$$

$$2\angle OAB = 180^\circ - 60^\circ = 120^\circ$$

$$\angle OAB = 60^\circ$$

Therefore, ΔOAB is an equilateral triangle.

$$\begin{aligned}\text{Area of } \Delta OAB &= \frac{\sqrt{3}}{4} \times (\text{side})^2 \\ &= \frac{\sqrt{3}}{4} \times (28)^2 = 196\sqrt{3} = 196 \times 1.7\end{aligned}$$

$$\text{Area of sector OAPB} = \frac{60^\circ}{360^\circ} \times \pi r^2$$

$$\begin{aligned}&= \frac{1}{6} \times \frac{22}{7} \times 28 \times 28 \\ &= \frac{1232}{3} \text{ cm}^2\end{aligned}$$

$$= 333.2 \text{ cm}^2$$

Area of segment APB = Area of sector OAPB – Area of ΔOAB

$$= \left(\frac{1232}{3} - 333.2 \right) \text{ cm}^2$$

$$\begin{aligned}\text{Therefore, area of designs} &= 6 \times \left(\frac{1232}{3} - 333.2 \right) \text{ cm}^2 \\ &= (2464 - 1999.2) \text{ cm}^2 \\ &= 464.8 \text{ cm}^2\end{aligned}$$

Cost of making 1 cm^2 designs = Rs 0.35

Cost of making 464.76 cm^2 designs = $464.8 \times 0.35 = \text{Rs } 162.68$

Therefore, the cost of making such designs is Rs 162.68.

Question 14:

Tick the correct answer in the following:

Area of a sector of angle p (in degrees) of a circle with radius R is

- (A) $\frac{p}{180} \times 2\pi R$ (B) $\frac{p}{180} \times \pi R^2$ (C) $\frac{p}{360} \times 2\pi R$ (D) $\frac{p}{720} \times 2\pi R^2$

Answer 14:

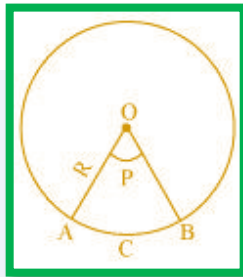

We know that area of sector of angle $\theta = \frac{\theta}{360^\circ} \times \pi R^2$

$$\begin{aligned} \text{Area of sector of angle } P &= \frac{p}{360^\circ} (\pi R^2) \\ &= \left(\frac{p}{720^\circ} \right) (2\pi R^2) \end{aligned}$$

Hence, (D) is the correct answer.

Mathematics

(Chapter – 12) (Areas Related to Circles)

(Class – X)

Exercise 12.3

Question 1:

Find the area of the shaded region in the given figure, if $PQ = 24$ cm, $PR = 7$ cm and O is the centre of the circle. [Use $\pi = \frac{22}{7}$]

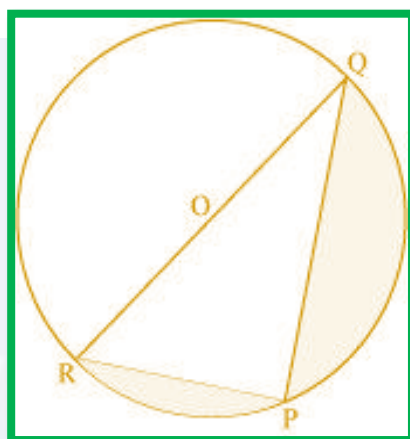

Answer 1:

It can be observed that RQ is the diameter of the circle. Therefore, $\angle RPQ$ will be 90° .

By applying Pythagoras theorem in ΔRPQ ,

$$RP^2 + PQ^2 = RQ^2$$

$$(7)^2 + (24)^2 = RQ^2$$

$$RQ = \sqrt{625} = 25$$

$$\text{Radius of circle, } OR = \frac{RQ}{2} = \frac{25}{2}$$

Since RQ is the diameter of the circle, it divides the circle in two equal parts.

$$\begin{aligned}
 \text{Area of semi-circle RPQOR} &= \frac{1}{2}\pi r^2 \\
 &= \frac{1}{2}\pi\left(\frac{25}{2}\right)^2 \\
 &= \frac{1}{2} \times \frac{22}{7} \times \frac{625}{4} \\
 &= \frac{6875}{28} \text{ cm}^2
 \end{aligned}$$

$$\begin{aligned}
 \text{Area of } \Delta PQR &= \frac{1}{2} \times PQ \times PR \\
 &= \frac{1}{2} \times 24 \times 7 \\
 &= 84 \text{ cm}^2
 \end{aligned}$$

Area of shaded region = Area of semi-circle RPQOR – Area of ΔPQR

$$= \frac{6875}{28} - 84$$

$$= \frac{6875 - 2352}{28}$$

$$= \frac{4523}{28} \text{ cm}^2$$

Question 2:

Find the area of the shaded region in the given figure, if radii of the two concentric circles with centre O are 7 cm and 14 cm respectively and $\angle AOC = 40^\circ$. [Use $\pi = \frac{22}{7}$]

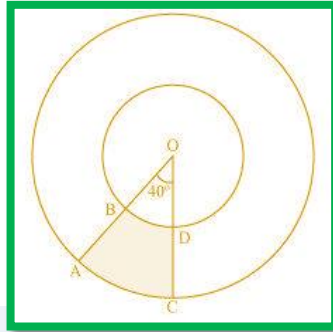

Answer 2:

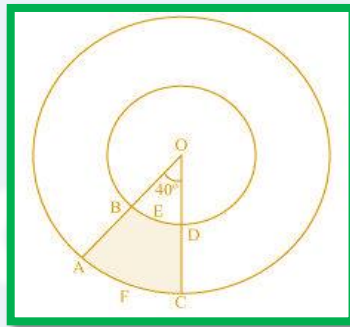

Radius of inner circle = 7 cm

Radius of outer circle = 14 cm

Area of shaded region = Area of sector OAFC – Area of sector OBED

$$\begin{aligned} &= \frac{40^\circ}{360^\circ} \times \pi(14)^2 - \frac{40^\circ}{360^\circ} \times \pi(7)^2 \\ &= \frac{1}{9} \times \frac{22}{7} \times 14 \times 14 - \frac{1}{9} \times \frac{22}{7} \times 7 \times 7 \\ &= \frac{616}{9} - \frac{154}{9} = \frac{462}{9} \\ &= \frac{154}{3} \text{ cm}^2 \end{aligned}$$

Question 3:

Find the area of the shaded region in the given figure, if ABCD is a square of side 14 cm and APD and BPC are semicircles. [Use $\pi = \frac{22}{7}$]

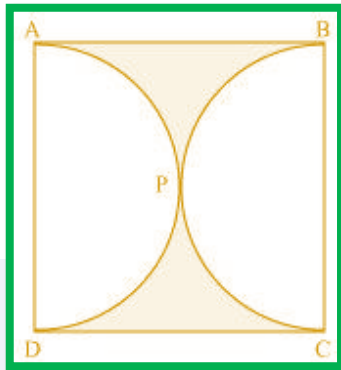

Answer 3:

It can be observed from the figure that the radius of each semi-circle is 7 cm.

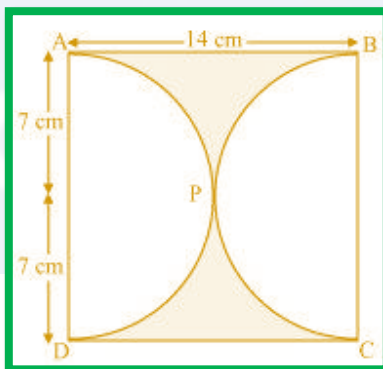

$$\begin{aligned}\text{Area of each semi-circle} &= \frac{1}{2} \pi r^2 \\ &= \frac{1}{2} \times \frac{22}{7} \times (7)^2 \\ &= 77 \text{ cm}^2\end{aligned}$$

$$\text{Area of square ABCD} = (\text{Side})^2 = (14)^2 = 196 \text{ cm}^2$$

$$\begin{aligned}\text{Area of the shaded region} &= \text{Area of square ABCD} - \text{Area of semi-circle APD} - \text{Area of semi-circle BPC} \\ &= 196 - 77 - 77 = 196 - 154 = 42 \text{ cm}^2\end{aligned}$$

Question 4:

Find the area of the shaded region in the given figure, where a circular arc of radius 6 cm has been drawn with vertex O of an equilateral triangle OAB of side 12 cm as centre.

[Use $\pi = \frac{22}{7}$]

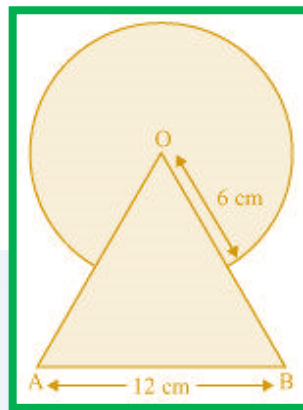

Answer 4:

We know that each interior angle of an equilateral triangle is of measure 60° .

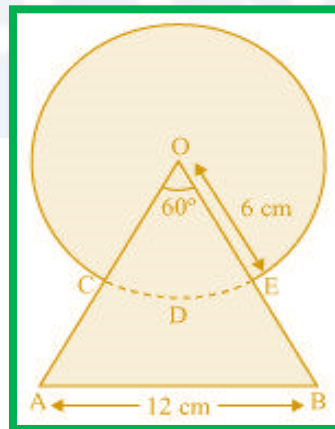

$$\text{Area of sector OCDE} = \frac{60^\circ}{360^\circ} \pi r^2$$

$$= \frac{1}{6} \times \frac{22}{7} \times 6 \times 6$$

$$= \frac{132}{7} \text{ cm}^2$$

$$\text{Area of } \Delta OAB = \frac{\sqrt{3}}{4} (12)^2 = \frac{\sqrt{3} \times 12 \times 12}{4} = 36\sqrt{3} \text{ cm}^2$$

$$\text{Area of circle} = \pi r^2 = \frac{22}{7} \times 6 \times 6 = \frac{792}{7} \text{ cm}^2$$

Area of shaded region = Area of ΔOAB + Area of circle – Area of sector OCDE

$$= 36\sqrt{3} + \frac{792}{7} - \frac{132}{7}$$

$$= \left(36\sqrt{3} + \frac{660}{7} \right) \text{ cm}^2$$

Question 5:

From each corner of a square of side 4 cm a quadrant of a circle of radius 1 cm is cut and also a circle of diameter 2 cm is cut as shown in the given figure. Find the area of the remaining portion of the square. [Use $\pi = \frac{22}{7}$]

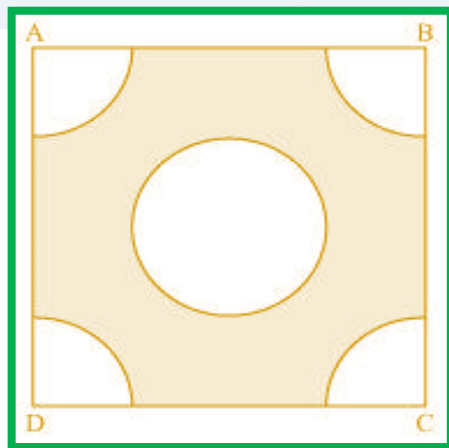

Answer 5:

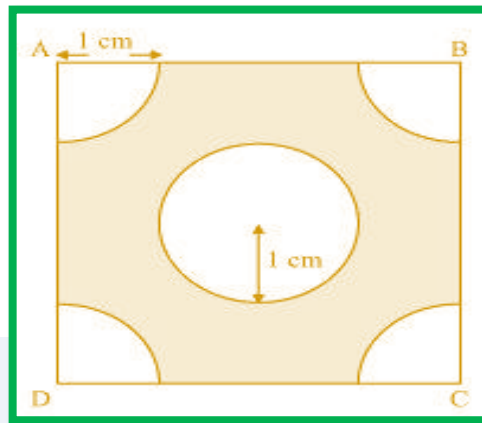

Each quadrant is a sector of 90° in a circle of 1 cm radius.

$$\text{Area of each quadrant} = \frac{90^\circ}{360^\circ} \pi r^2$$

$$= \frac{1}{4} \times \frac{22}{7} \times (1)^2 = \frac{22}{28} \text{ cm}^2$$

$$\text{Area of square} = (\text{Side})^2 = (4)^2 = 16 \text{ cm}^2$$

$$\text{Area of circle} = \pi r^2 = \pi (1)^2$$

$$= \frac{22}{7} \text{ cm}^2$$

Area of the shaded region = Area of square – Area of circle – $4 \times$ Area of quadrant

$$= 16 - \frac{22}{7} - 4 \times \frac{22}{28}$$

$$= 16 - \frac{22}{7} - \frac{22}{7} = 16 - \frac{44}{7}$$

$$= \frac{112 - 44}{7} = \frac{68}{7} \text{ cm}^2$$

Question 6:

In a circular table cover of radius 32 cm, a design is formed leaving an equilateral triangle ABC in the middle as shown in the given figure. Find the area of the design (Shaded region). [Use $\pi = \frac{22}{7}$]

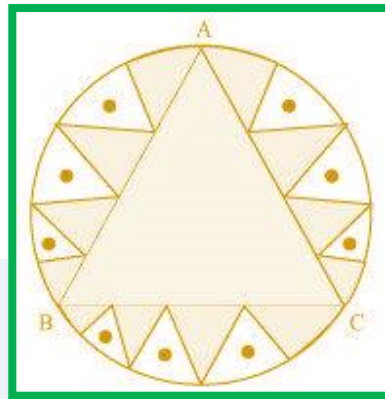

Answer 6:

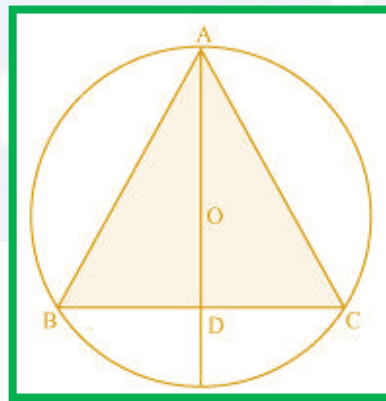

Radius (r) of circle = 32 cm

AD is the median of $\triangle ABC$

$$AO = \frac{2}{3} AD = 32$$

AD = 48 cm

In $\triangle ABD$,

$$AB^2 = AD^2 + BD^2$$

$$AB^2 = (48)^2 + \left(\frac{AB}{2}\right)^2$$

$$\frac{3AB^2}{4} = (48)^2$$

$$AB = \frac{48 \times 2}{\sqrt{3}} = \frac{96}{\sqrt{3}}$$

$$= 32\sqrt{3} \text{ cm}$$

Area of equilateral triangle, $\Delta ABC = \frac{\sqrt{3}}{4} (32\sqrt{3})^2$

$$= \frac{\sqrt{3}}{4} \times 32 \times 32 \times 3 = 96 \times 8 \times \sqrt{3}$$

$$= 768\sqrt{3} \text{ cm}^2$$

Area of circle = πr^2

$$= \frac{22}{7} \times (32)^2$$

$$= \frac{22}{7} \times 1024$$

$$= \frac{22528}{7} \text{ cm}^2$$

Area of design = Area of circle – Area of ΔABC

$$= \left(\frac{22528}{7} - 768\sqrt{3} \right) \text{ cm}^2$$

Question 7:

In the given figure, ABCD is a square of side 14 cm. With centres A, B, C and D, four circles are drawn such that each circle touches externally two of the remaining three circles. Find the area of the shaded region. [Use $\pi = \frac{22}{7}$]

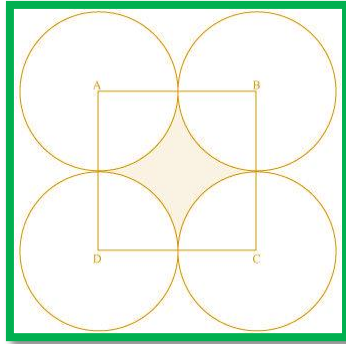

Answer 7:

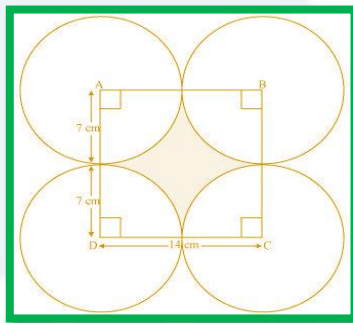

Area of each of the 4 sectors is equal to each other and is a sector of 90° in a circle of 7 cm radius.

$$\begin{aligned} \text{Area of each sector} &= \frac{90^\circ}{360^\circ} \times \pi(7)^2 \\ &= \frac{1}{4} \times \frac{22}{7} \times 7 \times 7 \\ &= \frac{77}{2} \text{ cm}^2 \end{aligned}$$

Area of square ABCD = (Side)² = (14)² = 196 cm²

Area of shaded portion = Area of square ABCD – 4 × Area of each sector

$$\begin{aligned} &= 196 - 4 \times \frac{77}{2} = 196 - 154 \\ &= 42 \text{ cm}^2 \end{aligned}$$

Therefore, the area of shaded portion is 42 cm².

Question 8:

The given figure depicts a racing track whose left and right ends are semicircular.



The distance between the two inner parallel line segments is 60 m and they are each 106 m long. If the track is 10 m wide, find:

(i) The distance around the track along its inner edge

(ii) The area of the track

[Use $\pi = \frac{22}{7}$]

Answer 8:

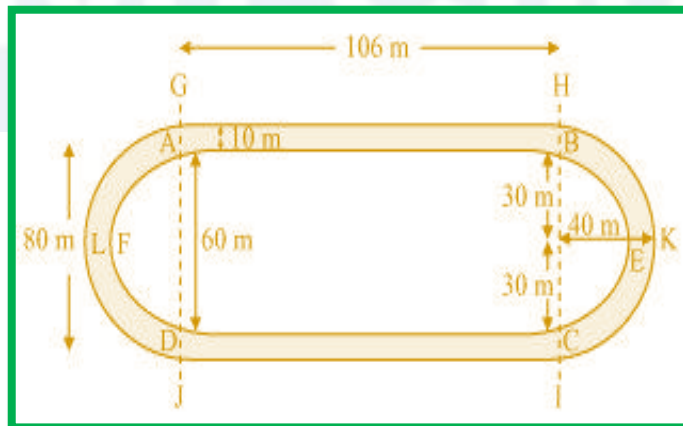

Distance around the track along its inner edge = AB + arc BEC + CD + arc DFA

$$\begin{aligned}
&= 106 + \frac{1}{2} \times 2\pi r + 106 + \frac{1}{2} \times 2\pi r \\
&= 212 + \frac{1}{2} \times 2 \times \frac{22}{7} \times 30 + \frac{1}{2} \times 2 \times \frac{22}{7} \times 30 \\
&= 212 + 2 \times \frac{22}{7} \times 30 \\
&= 212 + \frac{1320}{7} \\
&= \frac{1484 + 1320}{7} = \frac{2804}{7} \text{ m}
\end{aligned}$$

Area of the track = (Area of GHIJ – Area of ABCD) + (Area of semi-circle HKI – Area of semi-circle BEC) + (Area of semi-circle GLJ – Area of semi-circle AFD)

$$\begin{aligned}
&= 106 \times 80 - 106 \times 60 + \frac{1}{2} \times \frac{22}{7} \times (40)^2 - \frac{1}{2} \times \frac{22}{7} \times (30)^2 + \frac{1}{2} \times \frac{22}{7} \times (40)^2 - \frac{1}{2} \times \frac{22}{7} \times (30)^2 \\
&= 106(80 - 60) + \frac{22}{7} \times (40)^2 - \frac{22}{7} \times (30)^2 \\
&= 106(20) + \frac{22}{7} [(40)^2 - (30)^2] \\
&= 2120 + \frac{22}{7} (40 - 30)(40 + 30) \\
&= 2120 + \left(\frac{22}{7}\right)(10)(70) \\
&= 2120 + 2200 \\
&= 4320 \text{ m}^2
\end{aligned}$$

Therefore, the area of the track is 4320 m².

Question 9:

In the given figure, AB and CD are two diameters of a circle (with centre O) perpendicular to each other and OD is the diameter of the smaller circle. If OA = 7 cm, find the area of shaded region. [Use $\pi = \frac{22}{7}$]

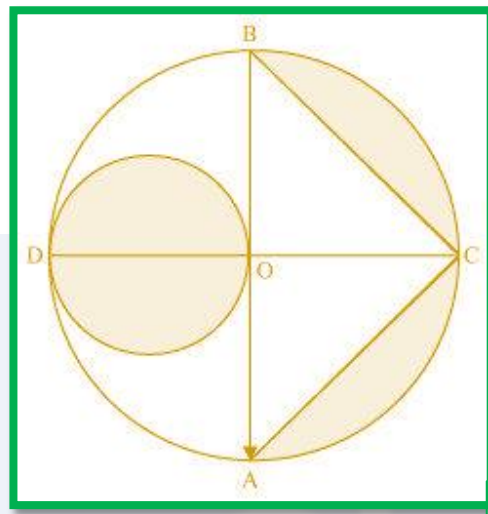

Answer 9:

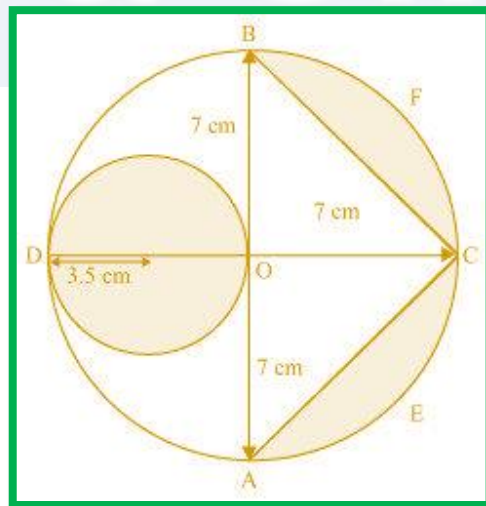

Radius (r_1) of larger circle = 7 cm

Radius (r_2) of smaller circle = $\frac{7}{2}$ cm

Area of smaller circle = πr_2^2

$$= \frac{22}{7} \times \frac{7}{2} \times \frac{7}{2}$$

$$= \frac{77}{2} \text{ cm}^2$$

Area of semi-circle AECFB of larger circle = $\frac{1}{2} \pi r_1^2$

$$= \frac{1}{2} \times \frac{22}{7} \times (7)^2$$

$$= 77 \text{ cm}^2$$

Area of $\triangle ABC = \frac{1}{2} \times AB \times OC$

$$= \frac{1}{2} \times 14 \times 7 = 49 \text{ cm}^2$$

Area of the shaded region

= Area of smaller circle + Area of semi-circle AECFB – Area of $\triangle ABC$

$$= \frac{77}{2} + 77 - 49$$

$$= 28 + \frac{77}{2} = 28 + 38.5 = 66.5 \text{ cm}^2$$

Question 10:

The area of an equilateral triangle ABC is 17320.5 cm^2 . With each vertex of the triangle as centre, a circle is drawn with radius equal to half the length of the side of the triangle (See the given figure). Find the area of shaded region. [Use $\pi = 3.14$ and $\sqrt{3} = 1.73205$]

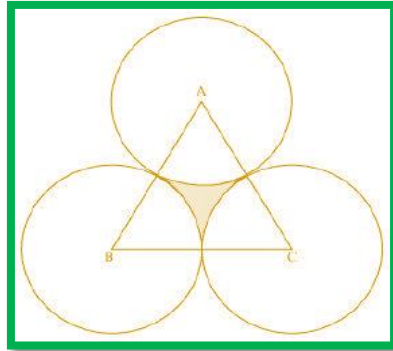

Answer 10:

Let the side of the equilateral triangle be a .

Area of equilateral triangle = 17320.5 cm^2

$$\frac{\sqrt{3}}{4}(a)^2 = 17320.5$$

$$\frac{1.73205}{4}a^2 = 17320.5$$

$$a^2 = 4 \times 10000$$

$$a = 200 \text{ cm}$$

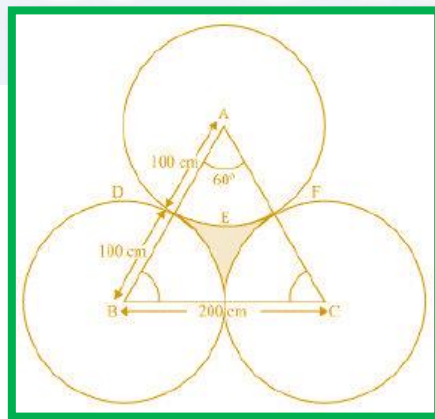

Each sector is of measure 60° .

$$\begin{aligned}
 \text{Area of sector ADEF} &= \frac{60^\circ}{360^\circ} \times \pi \times r^2 \\
 &= \frac{1}{6} \times \pi \times (100)^2 \\
 &= \frac{3.14 \times 10000}{6} \\
 &= \frac{15700}{3} \text{ cm}^2
 \end{aligned}$$

Area of shaded region = Area of equilateral triangle – 3 × Area of each sector

$$\begin{aligned}
 &= 17320.5 - 3 \times \frac{15700}{3} \\
 &= 17320.5 - 15700 = 1620.5 \text{ cm}^2
 \end{aligned}$$

Question 11:

On a square handkerchief, nine circular designs each of radius 7 cm are made (see the given figure). Find the area of the remaining portion of the handkerchief. [Use $\pi = \frac{22}{7}$]

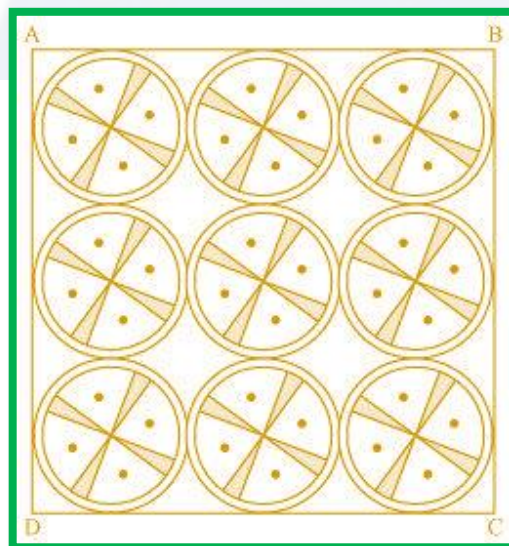

Answer 11:

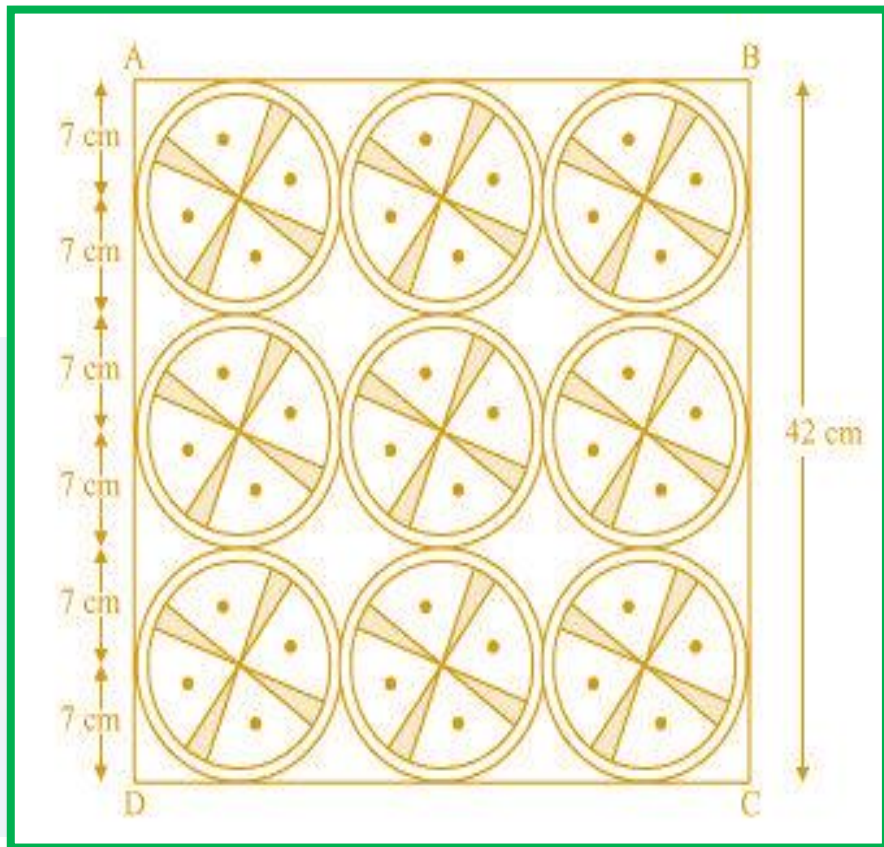

From the figure, it can be observed that the side of the square is 42 cm.

$$\text{Area of square} = (\text{Side})^2 = (42)^2 = 1764 \text{ cm}^2$$

$$\text{Area of each circle} = \pi r^2 = \frac{22}{7} \times (7)^2 = 154 \text{ cm}^2$$

$$\text{Area of 9 circles} = 9 \times 154 = 1386 \text{ cm}^2$$

$$\text{Area of the remaining portion of the handkerchief} = 1764 - 1386 = 378 \text{ cm}^2$$

Question 12:

In the given figure, OACB is a quadrant of circle with centre O and radius 3.5 cm. If OD = 2 cm, find the area of the

(i) Quadrant OACB

(ii) Shaded region

[Use $\pi = \frac{22}{7}$]

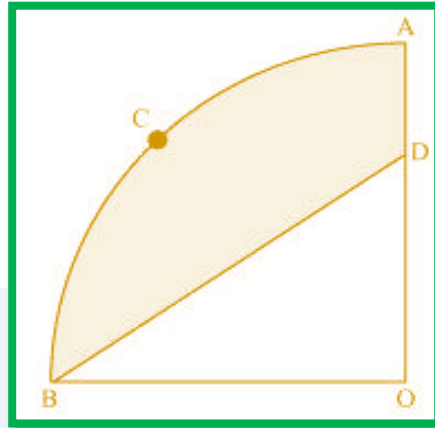

Answer 12:

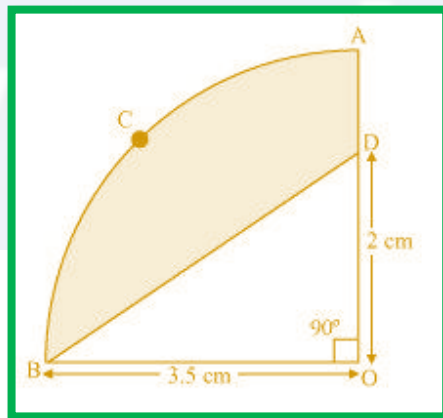

(i) Since OACB is a quadrant, it will subtend 90° angle at O.

$$\text{Area of quadrant OACB} = \frac{90^\circ}{360^\circ} \times \pi r^2$$

$$= \frac{1}{4} \times \frac{22}{7} \times (3.5)^2 = \frac{1}{4} \times \frac{22}{7} \times \left(\frac{7}{2}\right)^2$$

$$= \frac{11 \times 7 \times 7}{2 \times 7 \times 2 \times 2} = \frac{77}{8} \text{ cm}^2$$

(ii) Area of $\triangle OBD = \frac{1}{2} \times OB \times OD$

$$= \frac{1}{2} \times 3.5 \times 2$$

$$= \frac{1}{2} \times \frac{7}{2} \times 2$$

$$= \frac{7}{2} \text{ cm}^2$$

Area of the shaded region = Area of quadrant OACB – Area of $\triangle OBD$

$$= \frac{77}{8} - \frac{7}{2}$$

$$= \frac{77 - 28}{8}$$

$$= \frac{49}{8} \text{ cm}^2$$

Question 13:

In the given figure, a square OABC is inscribed in a quadrant OPBQ. If OA = 20 cm, find the area of the shaded region. [Use $\pi = 3.14$]

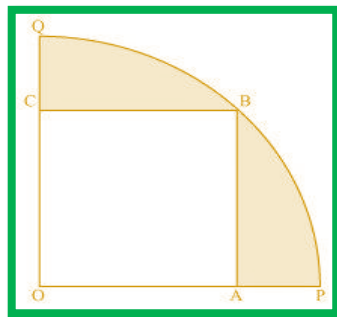

Answer 13:

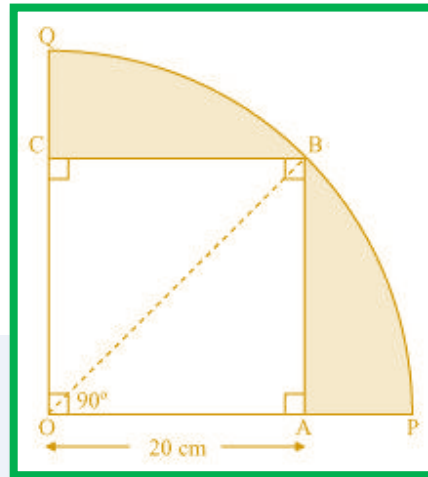

In $\triangle OAB$,

$$OB^2 = OA^2 + AB^2$$

$$= (20)^2 + (20)^2$$

$$OB = 20\sqrt{2}$$

$$\text{Radius } (r) \text{ of circle} = 20\sqrt{2} \text{ cm}$$

$$\text{Area of quadrant OPBQ} = \frac{90^\circ}{360^\circ} \times 3.14 \times (20\sqrt{2})^2$$

$$= \frac{1}{4} \times 3.14 \times 800$$

$$= 628 \text{ cm}^2$$

$$\text{Area of OACB} = (\text{Side})^2 = (20)^2 = 400 \text{ cm}^2$$

$$\text{Area of shaded region} = \text{Area of quadrant OPBQ} - \text{Area of OACB}$$

$$= (628 - 400) \text{ cm}^2$$

$$= 228 \text{ cm}^2$$

Question 14:

AB and CD are respectively arcs of two concentric circles of radii 21 cm and 7 cm and centre O (see the given figure). If $\angle AOB = 30^\circ$, find the area of the shaded region. [Use $\pi = \frac{22}{7}$]

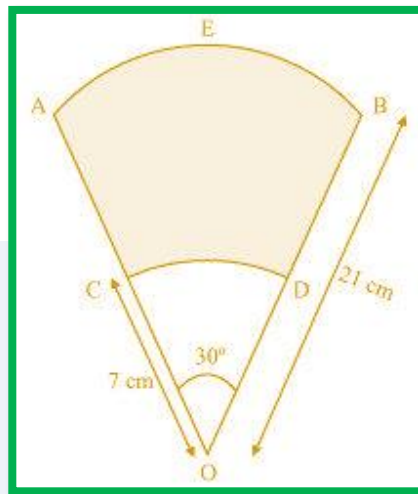

Answer 14:

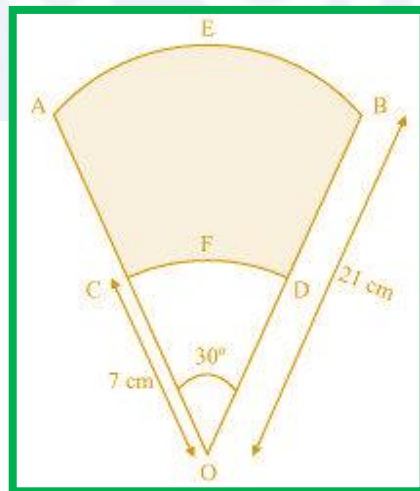

Area of the shaded region = Area of sector OAEB – Area of sector OCFD

$$\begin{aligned}
 &= \frac{30^\circ}{360^\circ} \times \pi \times (21)^2 - \frac{30^\circ}{360^\circ} \times \pi \times (7)^2 \\
 &= \frac{1}{12} \times \pi [(21)^2 - (7)^2] \\
 &= \frac{1}{12} \times \frac{22}{7} \times [(21-7)(21+7)] \\
 &= \frac{22 \times 14 \times 28}{12 \times 7} \\
 &= \frac{308}{3} \text{ cm}^2
 \end{aligned}$$

Question 15:

In the given figure, ABC is a quadrant of a circle of radius 14 cm and a semicircle is drawn with BC as diameter. Find the area of the shaded region. [Use $\pi = \frac{22}{7}$]

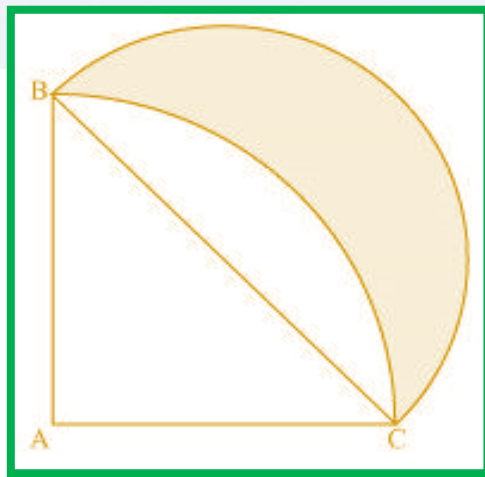

Answer 15:

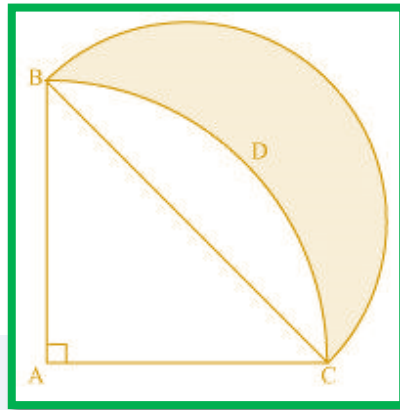

As ABC is a quadrant of the circle, $\angle BAC$ will be of measure 90° .

In $\triangle ABC$,

$$BC^2 = AC^2 + AB^2$$

$$= (14)^2 + (14)^2$$

$$BC = 14\sqrt{2}$$

Radius (r_1) of semi-circle drawn on $BC = \frac{14\sqrt{2}}{2} = 7\sqrt{2}$ cm

$$\text{Area of } \triangle ABC = \frac{1}{2} \times AB \times AC$$

$$= \frac{1}{2} \times 14 \times 14$$

$$= 98 \text{ cm}^2$$

$$\text{Area of sector} = \text{ABDC} = \frac{90^\circ}{360^\circ} \times \pi r^2$$

$$= \frac{1}{4} \times \frac{22}{7} \times 14 \times 14$$

$$= 154 \text{ cm}^2$$

$$\begin{aligned} \text{Area of semi-circle drawn on BC} &= \frac{1}{2} \times \pi \times r_1^2 = \frac{1}{2} \times \frac{22}{7} \times (7\sqrt{2})^2 \\ &= \frac{1}{2} \times \frac{22}{7} \times 98 = 154 \text{ cm}^2 \end{aligned}$$

Area of shaded region = Area of semi-circle – (Area of sector ABDC – Area of ΔABC)

$$= 154 - (154 - 98)$$

$$= 98 \text{ cm}^2$$

Question 16:

Calculate the area of the designed region in the given figure common between the two quadrants of circles of radius 8 cm each. [Use $\pi = \frac{22}{7}$]

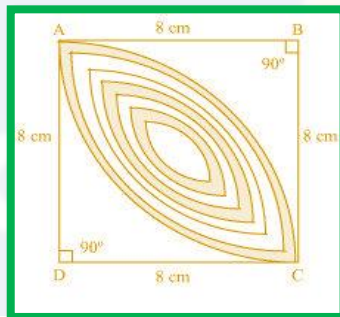

Answer 16:

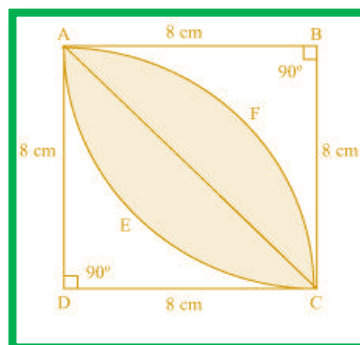

The designed area is the common region between two sectors BAEC and DAFC.

$$\begin{aligned}\text{Area of sector BAEC} &= \frac{90^\circ}{360^\circ} \times \frac{22}{7} \times (8)^2 \\ &= \frac{1}{4} \times \frac{22}{7} \times 64 \\ &= \frac{22 \times 16}{7} \\ &= \frac{352}{7} \text{ cm}^2\end{aligned}$$

$$\begin{aligned}\text{Area of } \triangle BAC &= \frac{1}{2} \times BA \times BC \\ &= \frac{1}{2} \times 8 \times 8 = 32 \text{ cm}^2\end{aligned}$$

Area of the designed portion = 2 × (Area of segment AEC)

= 2 × (Area of sector BAEC – Area of $\triangle BAC$)

$$\begin{aligned}&= 2 \times \left(\frac{352}{7} - 32 \right) = 2 \times \left(\frac{352 - 224}{7} \right) \\ &= \frac{2 \times 128}{7} \\ &= \frac{256}{7} \text{ cm}^2\end{aligned}$$